

# MIX 2:1<sup>™</sup>

## User Guide



Radial Engineering Ltd.  
1588 Kebet Way, Port Coquitlam BC V3C 5M5  
Tel: 604-942-1001 • Fax: 604-942-1010 • Email: [info@radialeng.com](mailto:info@radialeng.com)



# MIX 2:1 Two Channel Audio Combiner & Mixer

Overview.....	1
Features .....	2
Making Connections .....	3
Summing a Stereo Source to Mono .....	4
Summing Two Different Sources .....	5
Using the 180° and Ground Lift .....	6
Block Diagram .....	7
Specifications .....	8
Warranty .....	Back Cover



Thank you for purchasing the MIX 2:1™, a robust passive summing mixer that is a useful addition to any audio professional's toolbox. While the MIX 2:1 has been designed to be as easy to use as possible, please take a few minutes to review this short manual and familiarize yourself with the various features and uses of the MIX 2:1. If you find yourself in need of more information, please visit our website at [www.radialeng.com](http://www.radialeng.com), where we post frequently asked questions from users like yourself. Should you still have any questions, drop us a line at [info@radialeng.com](mailto:info@radialeng.com) and we will do our best to respond promptly.

## OVERVIEW

The MIX 2:1 is a simple summing mixer that makes merging two audio signals easy. Whether you need to sum mic or line level signals, or the outputs of two separate devices, the MIX 2:1 allows you to do so without noise or coloration of the sound. XLR and ¼" TRS inputs are provided for easy connectivity, with a single XLR output to feed your destination device. Level controls are available for each input that can be bypassed entirely to sum the left and right outputs of a mixing console or recording interface. A 180° polarity reverse switch opens up other options such as summing a snare top and bottom mic together to a single preamp, and ground lift switches help eliminate buzz and hum from ground loops.



## FEATURES

1. **On:** Individually activates each input.
2. **Input Level:** Sets the amount of attenuation applied to each input.
3. **180°:** Used to reverse the polarity on Input-2 to correct cancellation when summing out-of-phase signals.
4. **Level Bypass:** Set & forget switch bypasses the level controls on inputs 1 and 2. When this switch is engaged, both inputs are summed together equally.
5. **Output:** Mono XLR output is balanced to feed a powered speaker, mixing console, or a recording interface.
6. **Inputs:** TRS ¼" or XLR connectors are available for inputs 1 and 2.
7. **Ground Lifts:** Lifts the audio ground path on the XLR and ¼" inputs to reduce hum and buzz from ground loops.
8. **No Slip Pad:** Provides electrical & mechanical isolation and keeps the unit from sliding around.



## MAKING CONNECTIONS

Before making connections, ensure that your sound system is turned off and all volume controls are turned down. This prevents any plug-in transients from damaging speakers or other sensitive components. The MIX 2:1 is passive, and does not require any power to operate.

The MIX 2:1 has both  $\frac{1}{4}$ " TRS and an XLR connectors to accept balanced mic or line-level signals. For best results, only use one of these connector types at a time on each channel. The XLR output of the MIX 2:1 will also be mic or line level depending on your input sources and the amount of attenuation applied using the input level controls. Keep in mind that the MIX 2:1 does not provide any gain to the input signal, so if you connect two microphones to its inputs, you will still need to feed the output into a microphone preamp to boost the signal to line level.

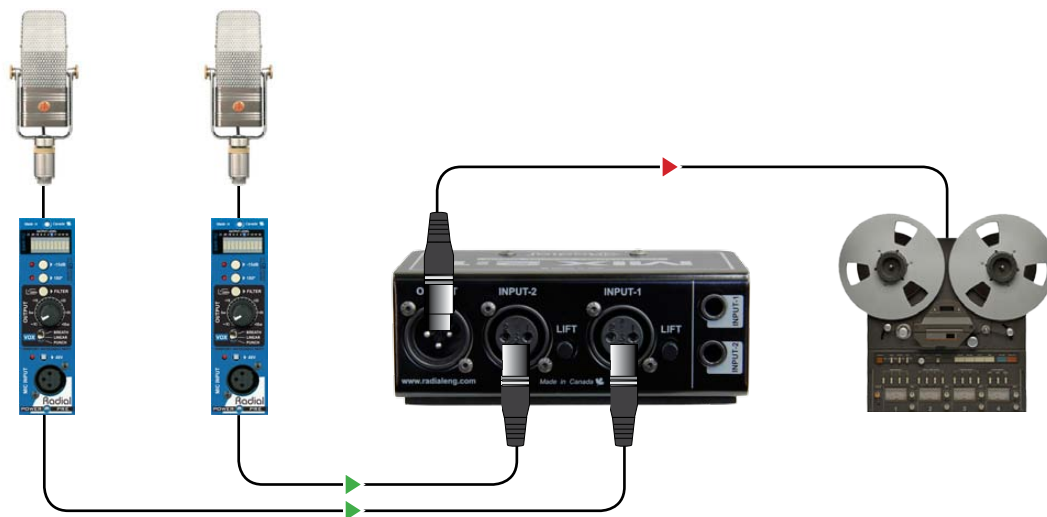

## SUMMING A STEREO SOURCE TO MONO

With the MIX 2:1, you can quickly take a stereo feed from a mixing console or a recording interface and sum it to mono to feed a single speaker input on a PA system. Start by pushing in the ON buttons for both inputs so they are both active. Next, engage the recessed LEVEL CONTROL BYPASS switch on the right hand side of the MIX 2:1 – this will disable the input level controls for each channel to ensure that the stereo balance is maintained.

The MIX 2:1 will automatically compensate for the 6dB in voltage gain that occurs when two in-phase signals are summed together so you won't distort the inputs of your destination device. Should you need to attenuate the levels, simply disengage the LEVEL CONTROL BYPASS and adjust each level control until you achieve the desired results.



## SUMMING TWO SEPARATE SOURCES

The MIX 2:1 is also handy for summing audio signals from two different devices, such as a guitar mic and a passive DI, or top and bottom snare drum mics. When summing two separate sources, start with the input level controls fully clockwise (max) and use the ON switches to audition each channel individually. If one signal is significantly louder than the other, use the level control on that channel to achieve the desired balance between the two signals

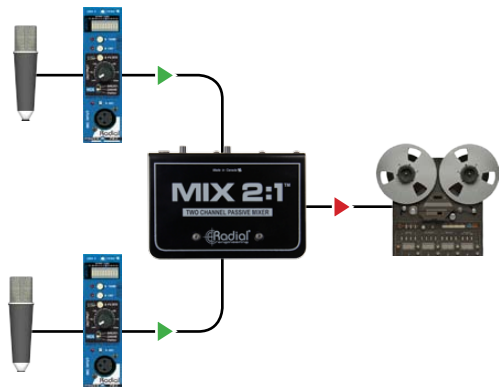

*Combine two line level outputs to a single input on your audio interface.*

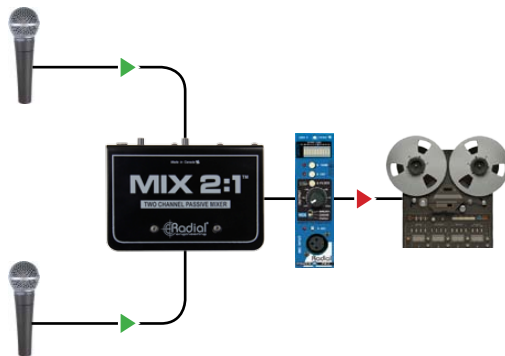

*The MIX 2:1 can also be used to sum two dynamic microphones together into a single mic preamp.*



## USING THE 180° SWITCH

The MIX 2:1 includes a 180° switch which reverses the polarity of the audio on INPUT-2 - this is sometimes referred to as a 'phase reverse'. When two audio signals have similar content but are reversed in polarity, certain frequencies can be cancelled or amplified when the signals are summed together, creating a filtered or unnatural sounding result. The 180° switch can be a quick way to reverse this effect and bring the signals back in alignment with each other, resulting in a fuller and more balanced sound.

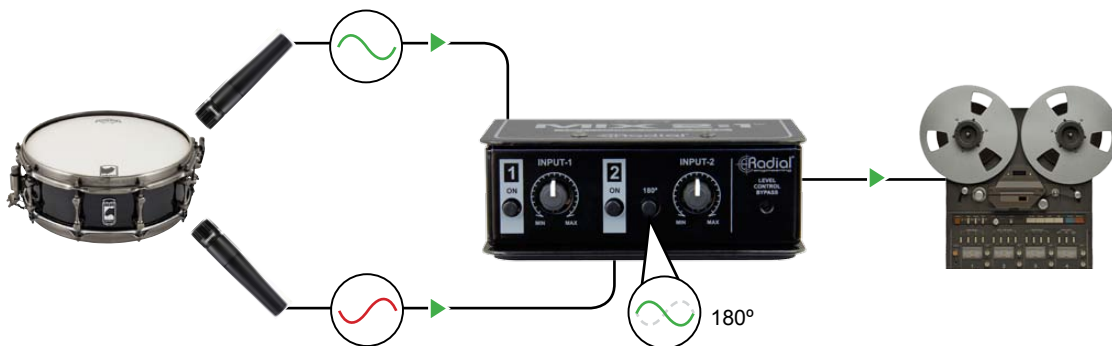

## USING THE GROUND LIFT

When connecting two or more powered devices to each other, you may encounter hum and buzz caused by ground loops. The MIX 2:1 is equipped with ground lift switches on both inputs; these disconnect pin-1 on the input connectors to break the electrical ground path and remove the noise. If you experience any hum or buzz when using the MIX 2:1, simply engage these ground lifts to help eliminate the problem.

### BLOCK DIAGRAM\*

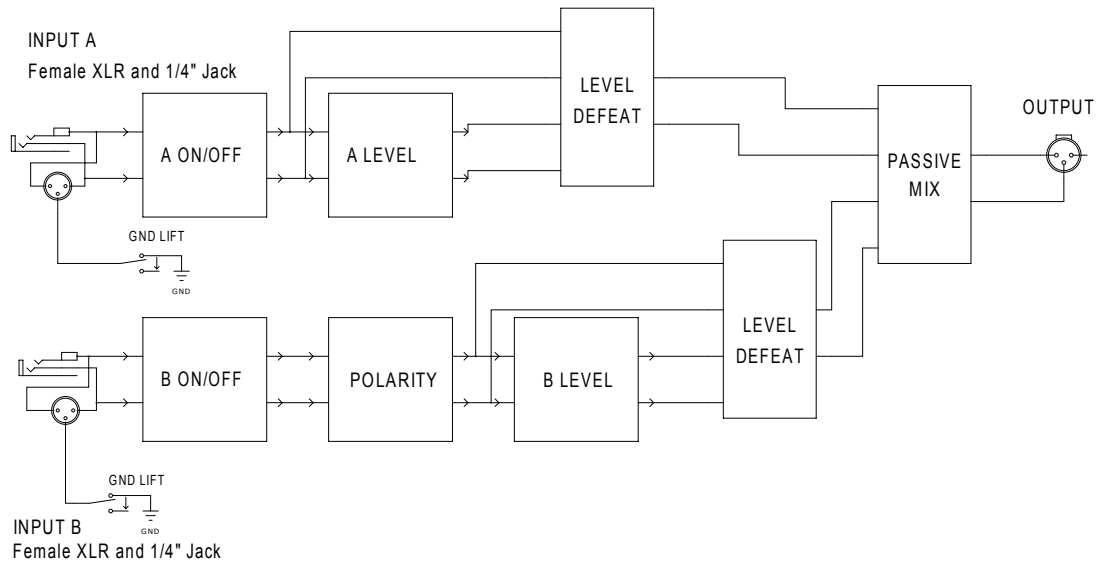

\* Subject to change without notice.

## SPECIFICATIONS\*

Audio Circuit Type: .....	Passive Mixer
Frequency Response: .....	20Hz-20kHz
Noise Floor: .....	-113dBu
Dynamic Range: .....	>133dBu
Maximum Input: .....	>+20dBu
Gain: .....	0dB
Intermodulation Distortion: .....	>0.002% @ 0dBu
Total Harmonic Distortion: .....	>0.005% @ 0dBu
Common-Mode Rejection Ratio: .....	>80dB
Phase deviation: .....	0° @ 20Hz, 0° @ 1kHz, +2° @ 10kHz
Input Impedance: .....	8k Ohms
Output Impedance: .....	1k Ohms
Insertion Loss: .....	-6dBu
Input connections: .....	1/4" / XLR
Switches: .....	180° phase, ground lift
Output Connector: .....	XLR
Power: .....	Passive, no power required
Construction: .....	14-gauge steel chassis & outer shell
Finish: .....	Durable Powder Coat
Size (L x W x D): .....	5"x3.312"x1.78" (LxWxD)
Warranty: .....	Radial 3-Year, transferable

\* Subject to change without notice.

## RADIAL ENGINEERING 3 YEAR TRANSFERABLE WARRANTY

RADIAL ENGINEERING LTD. ("Radial") warrants this product to be free from defects in material and workmanship and will remedy any such defects free of charge according to the terms of this warranty. Radial will repair or replace (at its option) any defective component(s) of this product (excluding finish and wear and tear on components under normal use) for a period of three (3) years from the original date of purchase. In the event that a particular product is no longer available, Radial reserves the right to replace the product with a similar product of equal or greater value. In the unlikely event that a defect is uncovered, please call 604-942-1001 or email [service@radialeng.com](mailto:service@radialeng.com) to obtain an RA number (Return Authorization number) before the 3 year warranty period expires. The product must be returned prepaid in the original shipping container (or equivalent) to Radial or to an authorized Radial repair center and you must assume the risk of loss or damage. A copy of the original invoice showing date of purchase and the dealer name must accompany any request for work to be performed under this limited and transferable warranty. This warranty shall not apply if the product has been damaged due to abuse, misuse, misapplication, accident or as a result of service or modification by any other than an authorized Radial repair center.

THERE ARE NO EXPRESSED WARRANTIES OTHER THAN THOSE ON THE FACE HEREOF AND DESCRIBED ABOVE. NO WARRANTIES WHETHER EXPRESSED OR IMPLIED, INCLUDING BUT NOT LIMITED TO, ANY IMPLIED WARRANTIES OF MERCHANTABILITY OR FITNESS FOR A PARTICULAR PURPOSE SHALL EXTEND BEYOND THE RESPECTIVE WARRANTY PERIOD DESCRIBED ABOVE OF THREE YEARS. RADIAL SHALL NOT BE RESPONSIBLE OR LIABLE FOR ANY SPECIAL, INCIDENTAL OR CONSEQUENTIAL DAMAGES OR LOSS ARISING FROM THE USE OF THIS PRODUCT. THIS WARRANTY GIVES YOU SPECIFIC LEGAL RIGHTS, AND YOU MAY ALSO HAVE OTHER RIGHTS, WHICH MAY VARY DEPENDING ON WHERE YOU LIVE AND WHERE THE PRODUCT WAS PURCHASED.



[www.radialeng.com](http://www.radialeng.com)

Radial Engineering Ltd.  
1588 Kebet Way, Port Coquitlam BC V3C 5M5  
Tel: 604-942-1001 • Fax: 604-942-1010 • Email: [info@radialeng.com](mailto:info@radialeng.com)



Radial MIX 2:1™ User Guide - Part #: R870 1036 00 / 10-2017 Copyright © 2017 All rights reserved.  
Appearance and specifications subject to change without notice.

Made in Canada

[www.radialeng.com](http://www.radialeng.com)