



True to the Music

SHOTGUN™

MIXER AND EFFECTS LOOP

User Guide



Radial Engineering Ltd.
1588 Kebet Way, Port Coquitlam BC V3C 5M5
Tel: 604-942-1001 • Fax: 604-942-1010 • Email: info@radialeng.com

SHOTGUN™ GUITAR SPLITTER AND BUFFER USER GUIDE

Introduction.....	1
Features	2
Overview.....	3
Making Connections.....	4-5
Using the Polarity Reverse.....	6
Using in Stereo.....	7
Extreme Application.....	8
Specifications	9
Warranty	Back Cover



Thank you for purchasing the Radial Shotgun, a powerful tool made for guitarists that insist on pushing great tone to the limit!

Although the Shotgun is super easy to use, we ask that you please take a couple of minutes to go through this short manual. This will not only help you maximize your tone, it will ensure you get the most out of the Shotgun with your setup. Once you are done, if you find yourself asking questions, please visit the FAQ page on our web site. This is where we post questions and answers for players like yourself. Then, if you still find yourself looking for more, we invite you to send us an email at info@radialeng.com and we will do our very best to reply in short order.

Now get ready to get more bang out of your amps than ever before!

FEATURES

1. **POWER:** Standard 9V connection for standard Boss-type power adaptor or DC brick. PSU is not included.
2. **OUT-1 DIRECT:** Used to connect to your first amp. Provides the Shotgun with a ground reference for safety.
3. **OUT-2, 3 & 4:** Transformer isolated outputs to eliminate ground loops and help reduce hum and buzz.
4. **IN-1 MONO:** When used alone, sets the Shotgun to the 1x4 mono mode with input-1 driving all four outputs.
5. **IN-2 STEREO:** When used, changes the circuit from 1x4 mono to 2x2 stereo to allow stereo sources such as a chorus to drive 1 or 2 sets of amps.
6. **POWER LED:** Lets you know the Shotgun power supply is properly connected.
7. **180°:** On outputs 2, 3 & 4 toggles the polarity of the outputs to ensure all your amps play in relative phase.
8. **LIFT:** On outputs 2, 3 & 4 lifts the audio ground to help prevent hum and buzz caused by ground loops.
9. **STEEL CASE:** Heavy 16-gauge steel case provides shielding from power supplies and keeps the internal electronics safe from abuse.

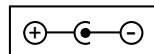
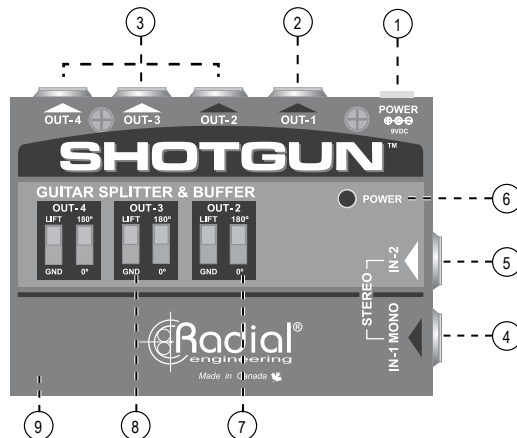

The Shotgun requires a 9 volt power supply with a negative center.

OVERVIEW

Technically speaking, the Shotgun is a unity gain guitar distribution amplifier. Simply put, it lets you drive several guitar amps at the same time without messing with your gain structure. What is particularly cool about the Shotgun is that it can be used either as a 1x4 (mono) distro or a 2x2 (stereo) distro depending on how it is connected.

Further, three of the Shotgun outputs are transformer isolated in order to prevent the hum and buzz that is commonly associated with ground loops. This means that you can drive all of your amps at the same time without the usual noise problems. It is also equipped with polarity reverse switches to ensure all of your amps play in phase. Best of all, it is super easy to use. Just plug in and enjoy!

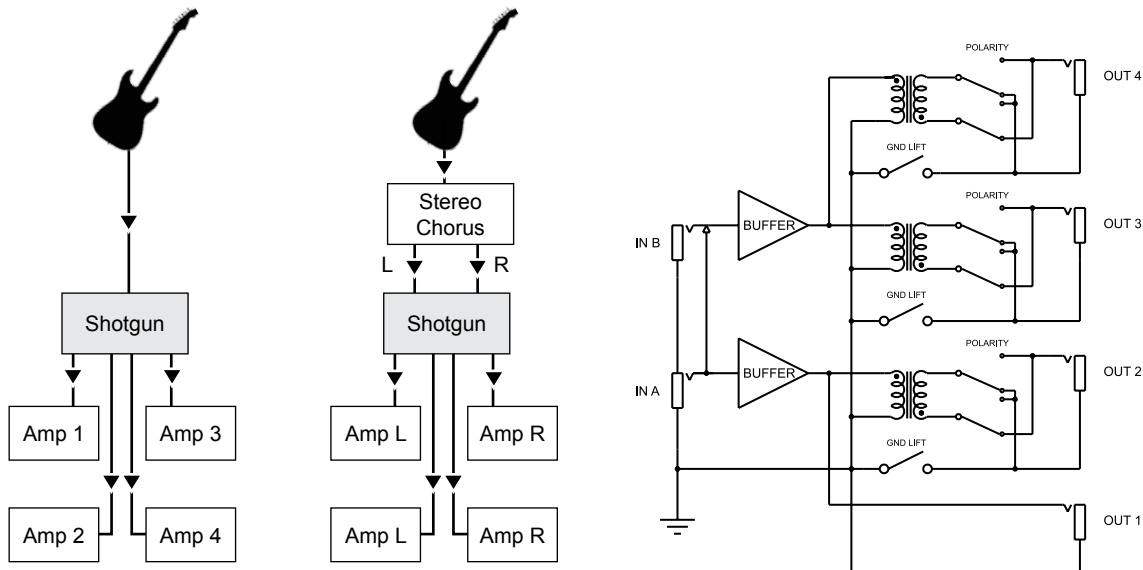

MAKING CONNECTIONS

Before making connections ensure your amplifiers are either turned off or volume turned down. This will avoid unpleasant plug-in transients that could shorten the lifespan of more sensitive components. Set all of the ground lift and 180° polarity reverse switches to the down position. Plug in your 9V power supply (not included). This should be a standard 'Boss' type guitar pedal adaptor or 9V supply from a multi-pedal power brick with a center negative connection. There is no power switch on the Shotgun. Once the power supply is connected, it will turn on and the top panel LED will illuminate to let you know power is on.

A handy cable lock is also available that will help prevent accidentally disconnecting the power. To use, unscrew the lock using a hex key, pass the wire through the clamp hole and retighten.

Connecting to and from the Shotgun is done using standard ¼" hi-Z coaxial guitar cables. Better quality, low-capacitance cables with 90% to 100% shield will improve signal-to-noise. Keeping cables as short as possible on the input side will further reduce susceptibility to noise. Once the signal has passed through the Shotgun, longer cables may be used as the Shotgun will buffer the signal and lower the impedance to enable cable distances up to 15 meters (50') without appreciable noise. The Shotgun is a unity gain device. Whatever signal you put in, it will put out - producing the same relative output volume.

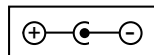

The Shotgun requires a 9 volt power supply with a negative center.

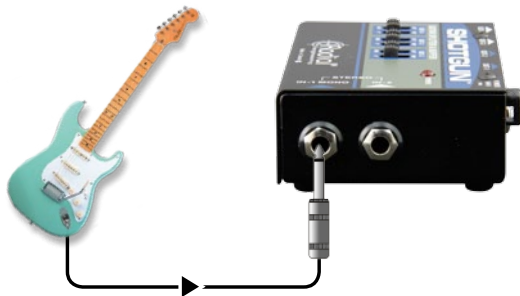

Start testing by connecting your guitar to input-1 and your amp to output-1. **Important note: output 1 is the default output and should always be used.** It is not isolated in order to provide the audio with a single ground path and should be connected to an amplifier with a proper electrical ground. For safety, always test at a low volume before increasing the levels. Turn up the volume on your amp. You should be getting a nice clean signal. Add your second amp by connecting it from the Shotgun's output-2. If you hear noise, try lifting the ground by pushing the output-2 ground lift switch in the up position. Repeat for any additional amplifiers.



If you encounter noise, try lifting the ground.

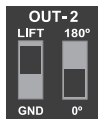

IMPORTANT SAFETY NOTICE: As you are the sole user of the Shotgun, you are entirely responsible for using amplifiers, power supplies and effects that are electrically approved by your local authority and are safe for use. If you are unsure of the status of your equipment, please contact the manufacturer or dealer for details. As Radial Engineering Ltd. is unable to control what is being connected to the Shotgun, you agree to take full responsibility for its safe use and agree that Radial Engineering Ltd. along with its staff and directors shall not be held responsible in any way for damages of any kind other than those clearly detailed in the Radial Warranty. Should you for any reason feel uncomfortable with the above statement, you should return the Shotgun before use to the dealer in the original packaging for full credit within 7 days of purchase.

Using the 180° polarity reverse

Using amp-1 (output-1) as your reference and amp-2 as the comparator, the easiest way to check to make sure your amps are in phase is to point them at each other, face-to-face or speaker-to-speaker. When you play, if the sound is thin or distant, you are likely out of phase. Simply push the 180° polarity reverse switch in the upward position to bring the two amps in phase. Repeat for amps 3 and 4 – always using amp-1 as the reference.

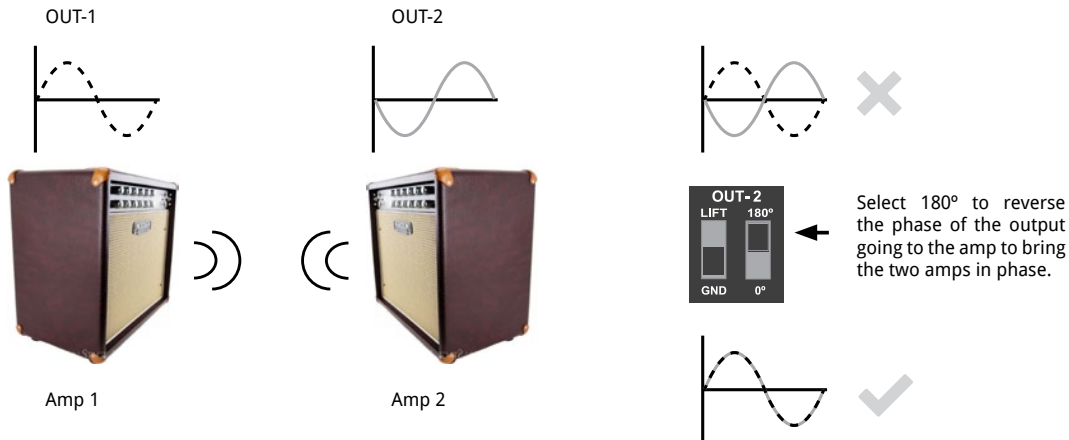

Using the Shotgun in stereo

In setups where you may have a stereo chorus or multi-tap delay on your pedalboard, sending the output from the stereo pedal to your amps will often cause hum and buzz due to a ground loop. This is because most pedals are not equipped with isolation transformers or ground lift switching to prevent noise.

Simply connect the left and right outputs from your chorus to the Shotgun's 1 and 2 inputs. Once connected to input-2, the Shotgun will automatically shift from mono-mode to stereo-mode. When in stereo-mode, input-1 is routed to outputs 1 and 2, while input-2 is routed to outputs 3 and 4. Connect output-1 to your left amp and output-3 to your right amp. You can then add two more amps on each side for larger stages.

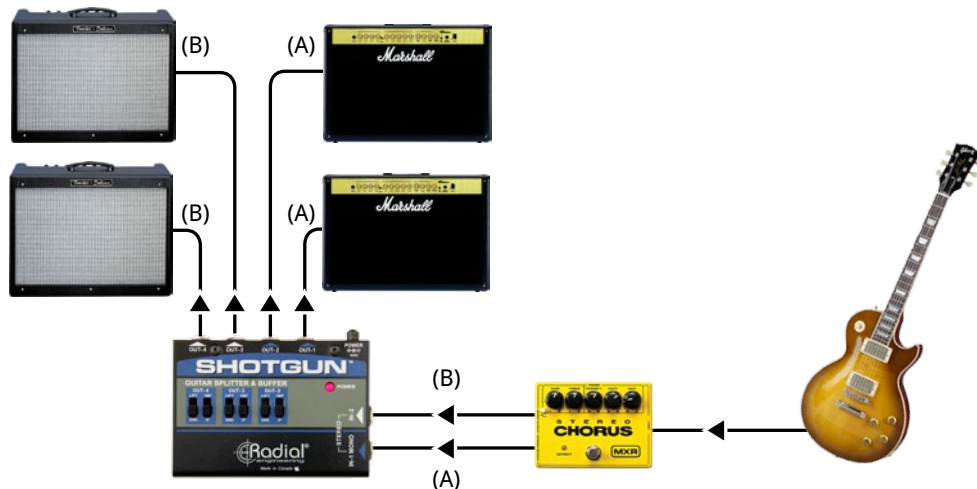

PUSHING THE SHOTGUN TO THE EXTREME

Experiment with using multiple outputs with your setup. Create unique tones by having two effect chains in parallel then merge them together using the Mix-Blender™. Have fun!

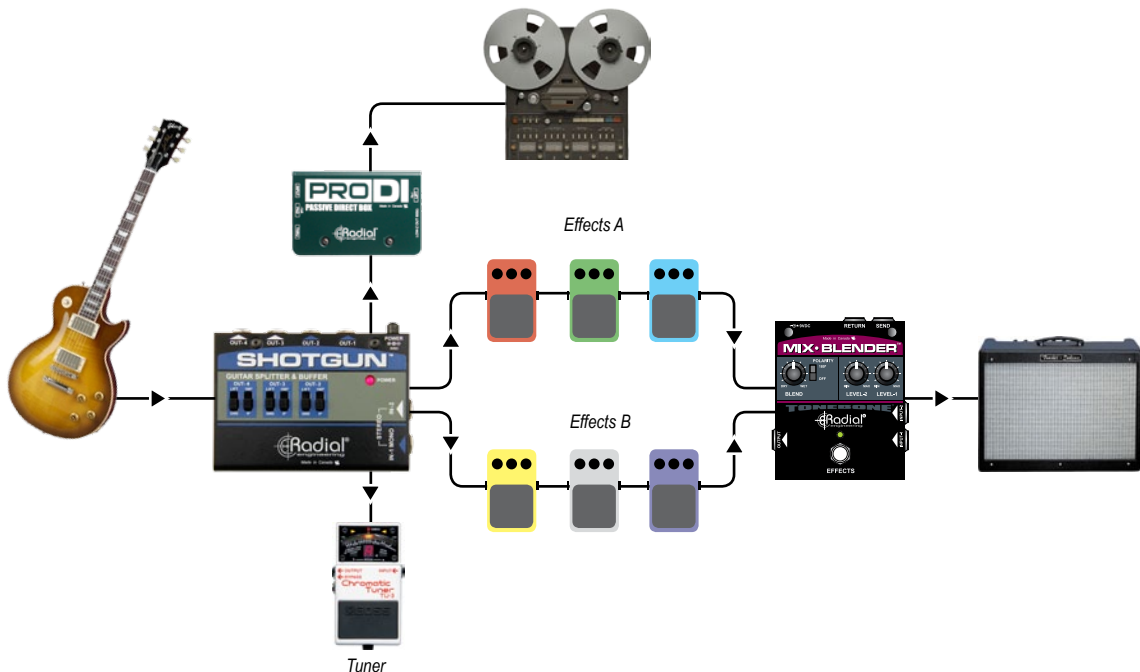

SPECIFICATIONS

Audio circuit type:	Buffered signal distribution with 3 isolated outputs
Frequency response:	20Hz to 20kHz (+0 / -2dB)
Total Harmonic Distortion: (THD+N)	<0.02% (-20dB)
Dynamic range:	>103dB/92dB (Out-1 / Out-2,3,4 - High Impedance Load)
Input impedance:	400K/200K (Stereo / Mono)
Maximum input:	> +8dBu
Gain:	0dB / -0.2dB (Out-1 / Out-2,3,4 - High Impedance Load)
Clip Level - Output:	> +7.5dBu
Output impedance:	100Ω / 1.8kΩ (Out-1 / Out-2,3,4)
Noise floor:	< -95dBu / -86dBu (Out-1 / Out-2,3,4)
Intermodulation distortion:	~0.02% (-20dB)
Power:	9V Adapter / 50mA
Construction:	Steel Enclosure
Size: (LxWxD)	4.5" x 3.62" x 1.37" (114.3 x 91.95 x 34.80mm)
Weight:	1.1lb (.49kg)
Warranty:	Radial 3-year, transferable

RADIAL ENGINEERING 3 YEAR TRANSFERABLE WARRANTY

RADIAL ENGINEERING LTD. ("Radial") warrants this product to be free from defects in material and workmanship and will remedy any such defects free of charge according to the terms of this warranty. Radial will repair or replace (at its option) any defective component(s) of this product (excluding finish and wear and tear on components under normal use) for a period of three (3) years from the original date of purchase. In the event that a particular product is no longer available, Radial reserves the right to replace the product with a similar product of equal or greater value. In the unlikely event that a defect is uncovered, please call 604-942-1001 or email service@radialeng.com to obtain a RA number (Return Authorization number) before the 3 year warranty period expires. The product must be returned prepaid in the original shipping container (or equivalent) to Radial or to an authorized Radial repair center and you must assume the risk of loss or damage. A copy of the original invoice showing date of purchase and the dealer name must accompany any request for work to be performed under this limited and transferable warranty. This warranty shall not apply if the product has been damaged due to abuse, misuse, misapplication, accident or as a result of service or modification by any other than an authorized Radial repair center.

THERE ARE NO EXPRESSED WARRANTIES OTHER THAN THOSE ON THE FACE HEREOF AND DESCRIBED ABOVE. NO WARRANTIES WHETHER EXPRESSED OR IMPLIED, INCLUDING BUT NOT LIMITED TO, ANY IMPLIED WARRANTIES OF MERCHANTABILITY OR FITNESS FOR A PARTICULAR PURPOSE SHALL EXTEND BEYOND THE RESPECTIVE WARRANTY PERIOD DESCRIBED ABOVE OF THREE YEARS. RADIAL SHALL NOT BE RESPONSIBLE OR LIABLE FOR ANY SPECIAL, INCIDENTAL OR CONSEQUENTIAL DAMAGES OR LOSS ARISING FROM THE USE OF THIS PRODUCT. THIS WARRANTY GIVES YOU SPECIFIC LEGAL RIGHTS, AND YOU MAY ALSO HAVE OTHER RIGHTS, WHICH MAY VARY DEPENDING ON WHERE YOU LIVE AND WHERE THE PRODUCT WAS PURCHASED.

To meet the requirements of California Proposition 65, it is our responsibility to inform you of the following:
WARNING: This product contains chemicals known to the State of California to cause cancer, birth defects or other reproductive harm.
Please take proper care when handling and consult local government regulations before discarding.

All trademarks belong to their respective owners. All references to these are for example only and are not associated with Radial.



www.radialeng.com

Radial Engineering Ltd.
1588 Kebet Way, Port Coquitlam BC V3C 5M5
Tel: 604-942-1001 • Fax: 604-942-1010 • Email: info@radialeng.com



Radial Shotgun™ User Guide - Part #: R870 1014 00 Copyright © 2016, all rights reserved.
Appearance and specifications subject to change without notice.

Made in Canada

www.radialeng.com