

ProD8 Rackmount DI

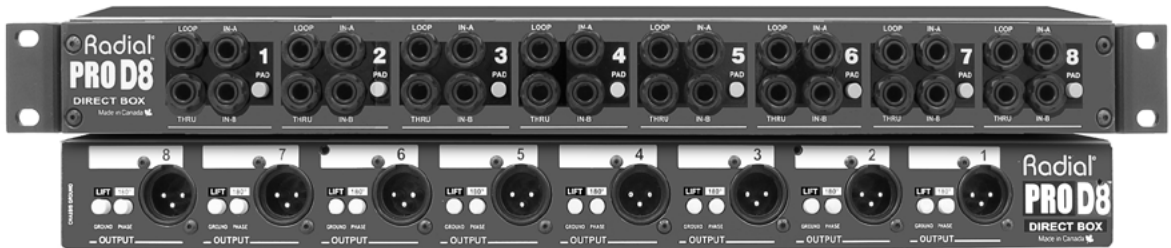

Owner's Manual

www.radialeng.com

Radial Engineering Ltd.
1845 Kingsway Ave. Port Coquitlam, BC V3C 0H3, Canada
Tel: 604-942-1001 • Fax: 604-942-101 • Email: info@radialeng.com

Radial ProD8 Owner's Manual

TABLE OF CONTENTS	PAGE
Introduction	Inside Cover
ProD8 Overview	1
Feature Functions	2
Rackmounting	3
Using the ProD8	4
Adding Effects	5
Typical Stage Set-up	6
Redundant Inputs for Backup Instruments	7
Redundant Inputs for Backup Playback	8
FAQ	9
Warranty Information.....	Back Cover

Congratulations on your purchase of the Radial ProD8.

The Radial ProD8 is a simple yet remarkably clever direct box in that it provides all of the standard features one would find in a typical rackmount DI plus several refinements: First off, it jams eight (8) direct boxes into a single rack space making it the highest density DI on the market. Secondly, it is equipped with redundant inputs on each channel that are pre-merged mono to reduce mixer and snake channel requirements or can be used as redundant inputs for system backup. Thirdly, an effects-loop on each channel lets you share your effect with two devices saving money and space. And finally, reversible rack rails let you position the inputs and the outputs on the front or back of the rack to best accommodate your live or studio set-up.

As with all Radial products, we highly recommend that you read this short manual before using the ProD8 so that you become familiar with all of the features and functions to get the most out of this device. Should you have any questions, please visit the FAQ section on our Radial web site as this is where we post the latest applications. You can also email us at info@radialeng.com should you have a question that is not answered.

We are confident that you will enjoy years of trouble free performance with your new Radial ProD8 and we look forward to hearing back from you about new an innovative ways you have found to use it. Now start reading and plugging away!

OVERVIEW

The Radial ProD8 is an 8 channel passive direct box and does not require any powering whatsoever to make it work. The high performance Radial transformers are extremely efficient and will both balance the signal and convert the high source impedance of your keyboards to a balanced, mic level low impedance output.

All channels are identical and completely isolated. Each channel features two inputs that are merged to mono using a resistive mixer. This means you can use either input for a mono source. If you have a stereo source such as a synthesizer or digital piano, connecting the instrument to the two inputs will yield a mono mix at the XLR output. Should you wish to connect a high output device like a CD player to the ProD8, a -15dB PAD will reduce the input level going to the transformer to avoid saturation. The ¼" THRU is a direct feed that would be used for your personal monitoring system.



To further advantage the user, an effects-loop has been provided that allows the two inputs on each channel to share the same effects processor. Each channel features an internal switch that lets you assign the THRU output either pre or post the effects-loop depending on how you intend to use the system.

BLOCK DIAGRAM

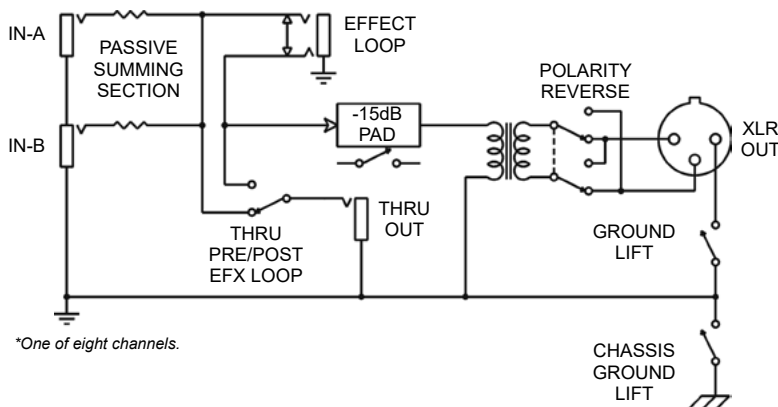

As previously mentioned, the 'engine' inside the ProD8 is the Radial transformer. This 'hi-Z to lo-Z' device is designed to convert the impedance and balance the signal so that it matches the level of a typical microphone. This way, the keyboards connected to the ProD8 can be 'managed' just like microphones and used with mic splitters as well as the mic inputs on the mixing console. A polarity reverse switch toggles pins 2 and 3 to allow older pre-AES standard gear to be connected in phase.

Transformers are particularly advantageous with keyboards and other devices that are electrically powered through the common AC electrical system as they isolate the input from the output to help eliminate hum and buzz caused by ground loops. A ground-lift switch further helps reduce noise by disconnecting pin-1 on the XLR thus allowing the system tech to derive the channel ground from either the input or the output.

1/4" PHONE PANEL

- ① **REVERSABLE RACK EARS** allow you to setup the ProD8 with either the 1/4" jacks or XLR connectors facing front.
- ② **IN-A/B** dual inputs on each channel auto-merge to mono.
- ③ **THRU** parallel thru-put connects to on-stage amp or mixer for personal monitoring.
- ④ **LOOP** each channel features an effects-loop on a TRS jack. Works like an insert on a mixing console.
- ⑤ **-15dB PAD** reduces the input level by -15dB to prevent overload from high output devices.

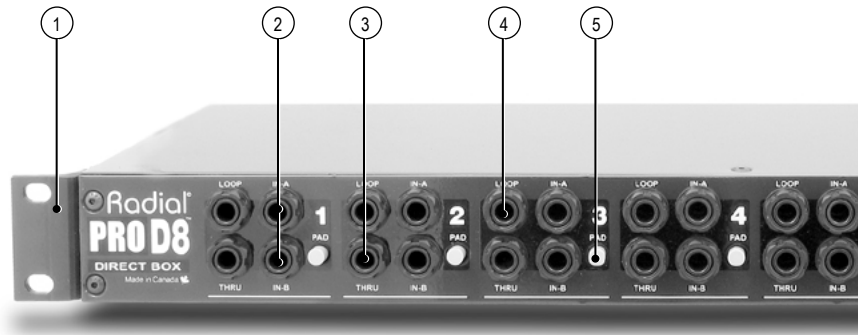

XLR PANEL

- ⑥ **XLR OUTPUTS** are balanced 600 ohm, mic-level and 100% transformer-isolated to prevent ground loops.
- ⑦ **LIFT** disconnects pin-1 on the XLR output to isolate ground via the transformer.
- ⑧ **180°** reverses pins 2 & 3 on the XLR inverting the signal polarity to correct out-of-phase signals.

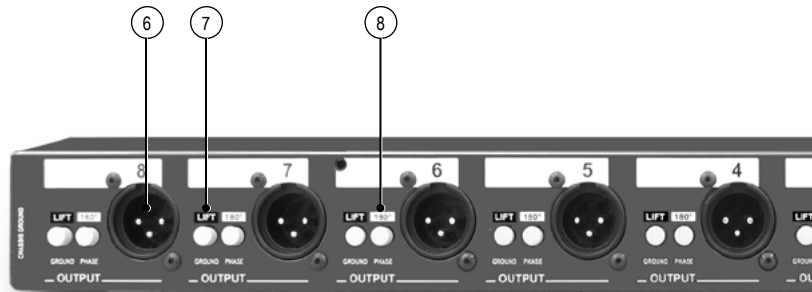

INTERNAL

- ⑨ **WELDED 14-GUAGE STEEL** rackmount enclosure is finished in durable baked enamel.
- ⑩ **RADIAL TRANSFORMER** with linear frequency response from 20Hz to 18KHz for natural sound. Mu-metal shield blocks electromagnetic interference.
- ⑪ **PRE/POST EFX** internal switch allows the THRU output to be pre or post the effects-loop. *Factory set to post effects-loop.*
- ⑫ **CHASSIS GROUND** internal switch allows individual ground paths for each channel. *Factory set in the lifted position.*
- ⑬ **MILITARY-GRADE** double-sided PCB is bolted to steel standoffs for toughness.
- ⑭ **ISOLATED CONNECTORS** extremely tough glass-filled nylon for true channel isolation from chassis ground.

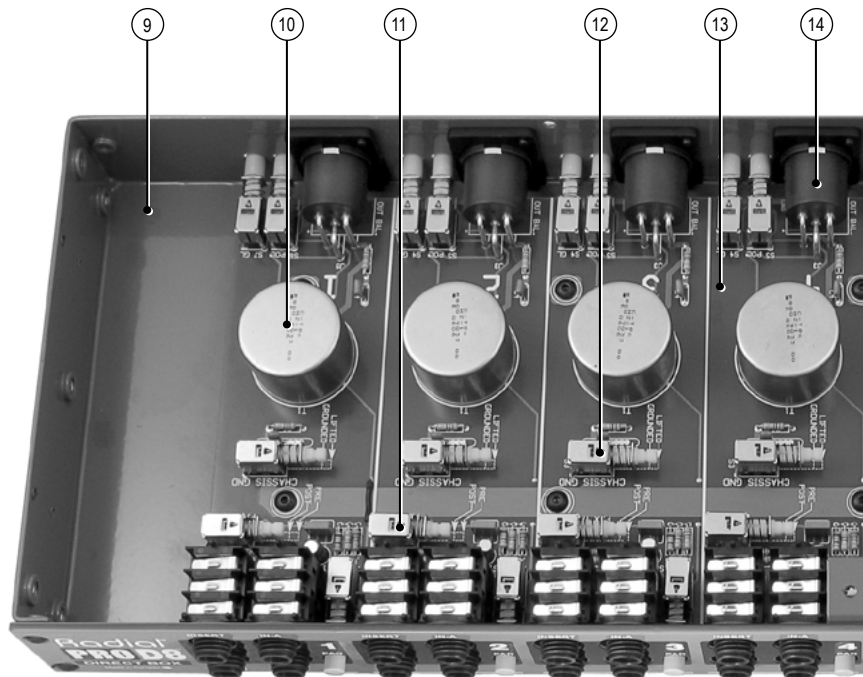

RACKMOUNT OPTIONS

Reversible rack rails allow you to decide which connector panel faces the front of your rack. Depending on your system setup, you may want to have the XLRs facing 'out' of your rack and the ¼" inputs and thru-puts on the inside. This would be the most common approach especially if you are using a number of rack-mounted sound modules.

Some system techs prefer to have access to the ¼" inputs. They will then have an XLR or multi-pin breakout panel made to connect the snake systems. This approach is useful when using the ProD8 with non-rack-mounted instruments.

The ProD8 can accommodate both setups. Simply unscrew the two large Phillips screws on the rack ear, loosen the center screw and rotate the rack ear to the side that works best for you. Re-insert the screws so that they are nice and tight and you are ready to go!

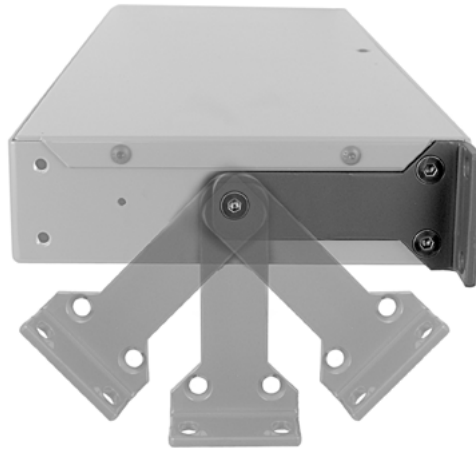

CHASSIS GROUNDING

The Radial ProD8 is equipped with a threaded ground lug on the chassis to allow star grounding. The ground lug connection, along with the internal chassis ground switch, would likely only be used in complex stage set-ups where extreme noise problems may occur. We suggest you speak with a qualified technician should you plan to use alternate grounding schemes.

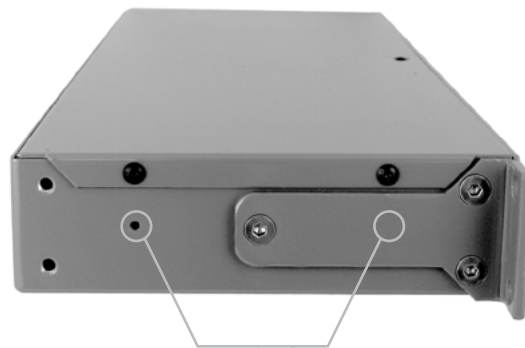

*Threaded ground lug connections
(one obscured by rack ear).*

USING THE RADIAL ProD8

For live touring, the most common approach to using a direct box is to connect the instrument to the A/B inputs, your personal monitoring amp system from the THRU and the balanced XLR output to the PA system. The Radial ProD8 of course does this and then multiplies this by eight. Since the ProD8 is so flexible, the following diagrams show some of the system set-ups that you could apply.

8 MONO KEYBOARDS

As described above, the ProD8 is plug & play easy to use as any standard passive DI. Connect an instrument to either input, the THRU to a monitor system and the XLR out to a mixer.

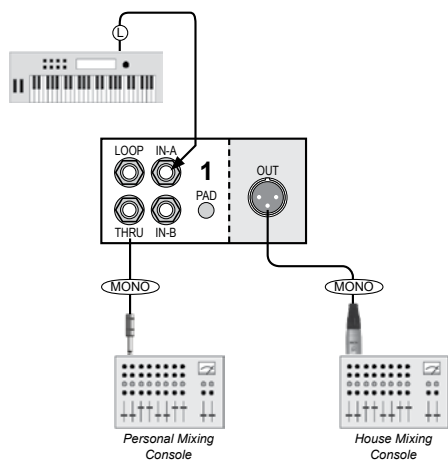

8 MERGED MONO KEYBOARDS

Stereo keyboards can easily be merged to mono to save snake and mixer channels. Connect the stereo keyboard to the A/B inputs on one ProD8 channel. The signal is merged to mono.

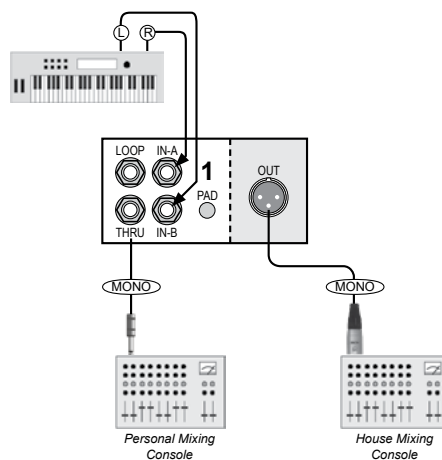

4 STEREO KEYBOARDS

You can set up 4 stereo keyboards and have them all play in stereo. Connect the keyboard stereo out two ProD8 channels.

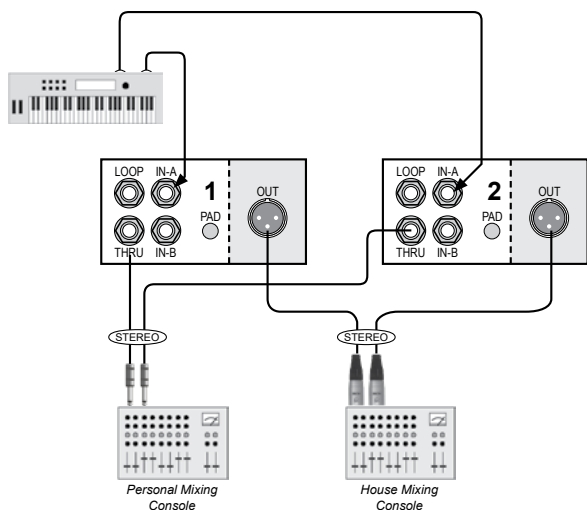

8 MERGED STEREO KEYBOARDS

You can set up 8 stereo keyboards and have them all play in stereo by using the dual A/B inputs on two ProD8 channels.

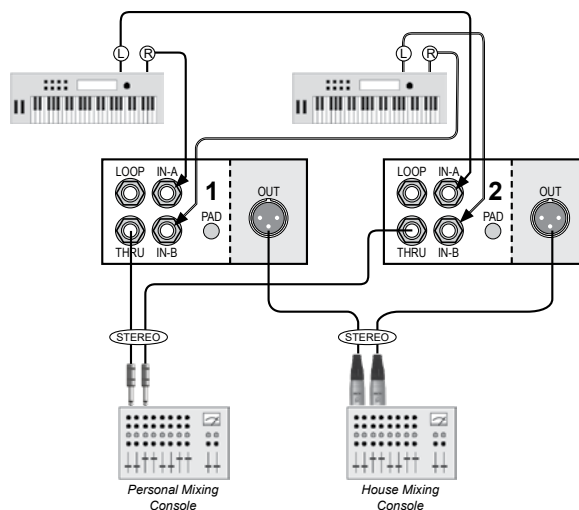

ADDING EFFECTS

The LOOP jack on each channel works like an "insert" connection on a mixing console. The LOOP jack is a TRS type that can send the signal out to a processor and return it to the ProD8 signal path. Connect the input and output of an effects processor to the LOOP jack using an "insert cable" which may be purchased at a music retailer.

Each channel is fitted with an internal EFX PRE/POST switch. The position of this switch determines if the THRU output will be PRE or POST the effects-loop. When the switch is set to PRE, the THRU output will be unaffected by the effects-loop. When the switch is set to POST, the effect processor will be heard at the THRU output. The XLR output is always POST effects-loop. *The ProD8 ships factory set to post effects-loop so a processor in the loop will be heard on all outputs.*

MONO EFFECTS

When one ProD8 channel is configured for a mono keyboard connect the LOOP jack to the input and output of the effects processor with one insert cable. If the dual A/B inputs on a ProD8 channel are used to connect two mono keyboards the effects processor is shared between them. This can save mixer channels and money. This also lets you share effects when running redundant modules for backup.

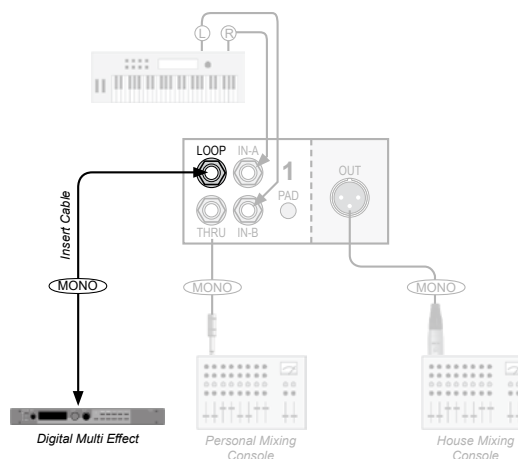

STEREO EFFECTS

When two of the ProD8 channels are configured for a stereo keyboard, connect the LOOP jacks on both channels to the left and right inputs/outputs of a stereo effect processor with two insert cables. If the dual A/B inputs on a ProD8 channel are used to connect two stereo keyboards the effects processor is shared between them.

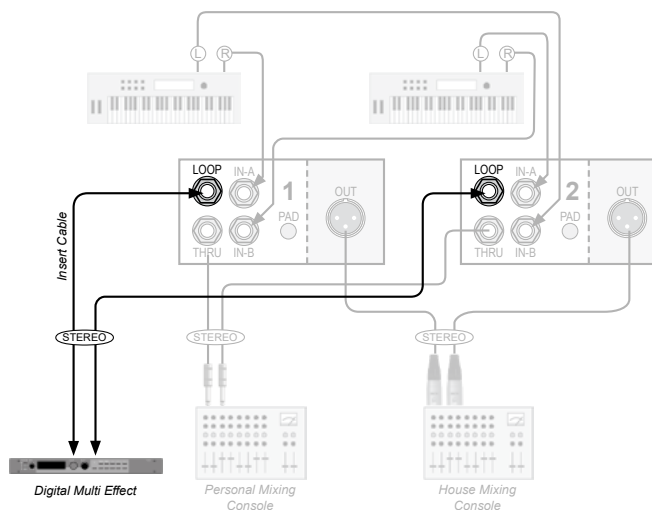

FLEXIBLE FOR LARGE KEYBOARD SETUPS

It is important to note that channels may be configured in different ways. For instance, in the example below channels 1 and 2 are used for a stereo master keyboard and a pre-patched backup that is ready to go. Channels 3 through 6 are used for mono sound modules. Channels 7 and 8 are set up in stereo for a drum machine with a stereo effect processor. All the instruments are connected to a personal monitor mixer via the THRU outputs and to a main mixer through the XLR outs.

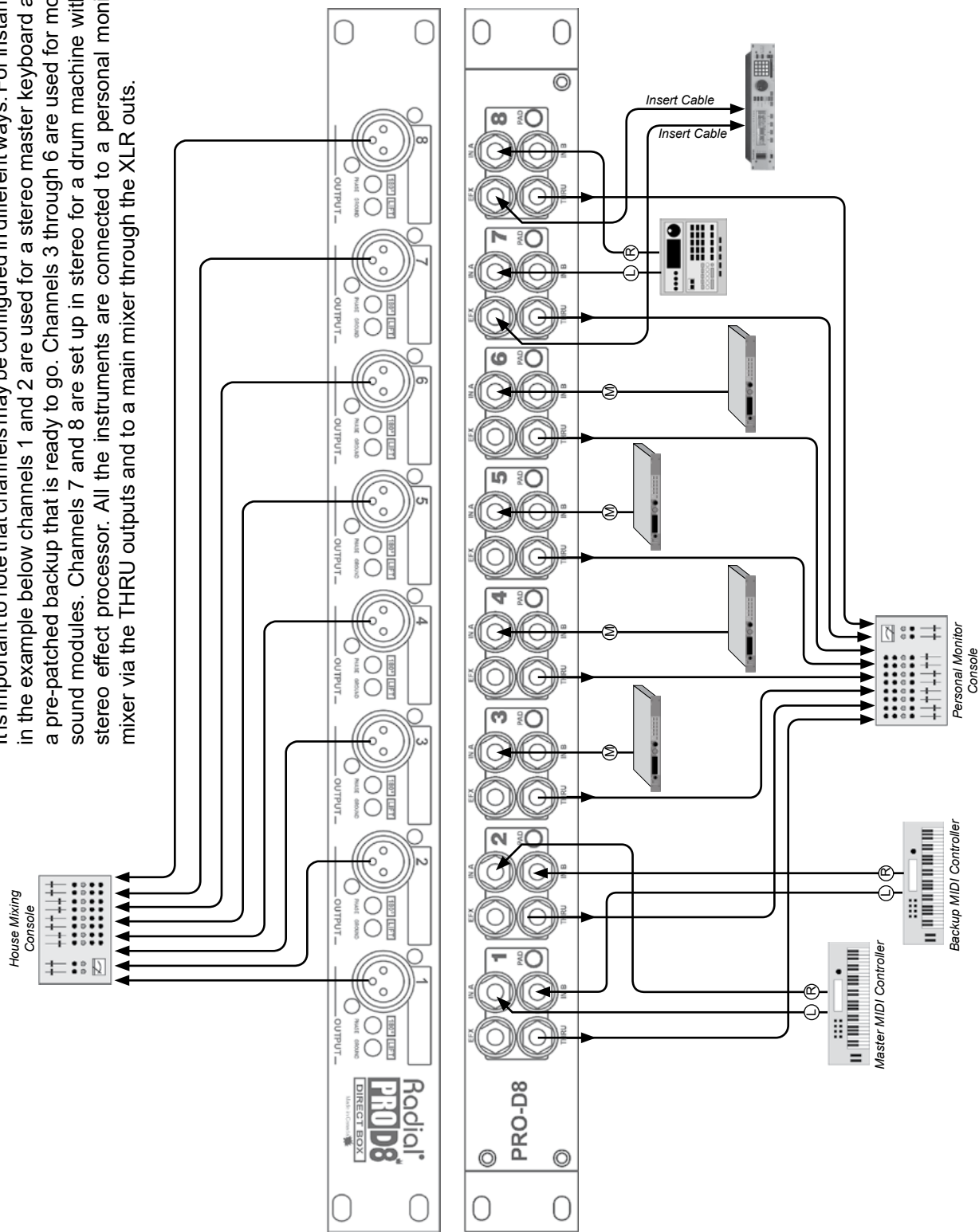

REDUNDANT MODULAR KEYBOARDS

Major concert tours cost millions to setup. Today, keyboard players often travel with back-ups to minimize downtime should a module fail. The merged inputs allow a second set of modules or keyboards to be connected in standby should a back-up be needed.

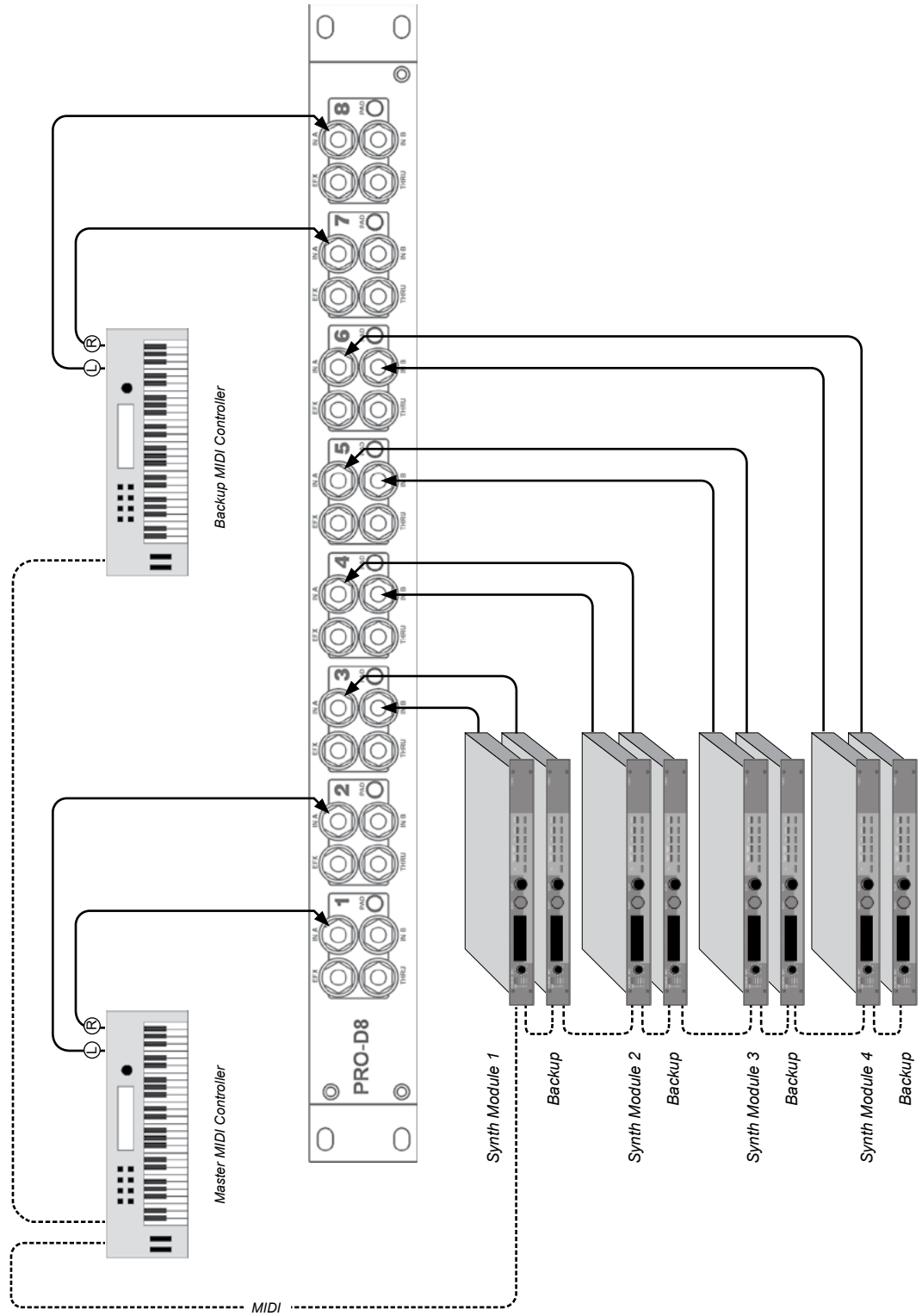

REDUNDANT BACK-UP TRACKS

The use of backing tracks has become common in today's concerts as fans expect to hear the full orchestration and backing vocals of their favorite songs. The ProD8 provides an effective means to connect two tape recorders via the dual A/B merged inputs on each channel. Simply place the back-up recorder on mute and sync both machines together. Should a problem occur, mute the main playback recorder and un-mute the backup system. The show will go on!

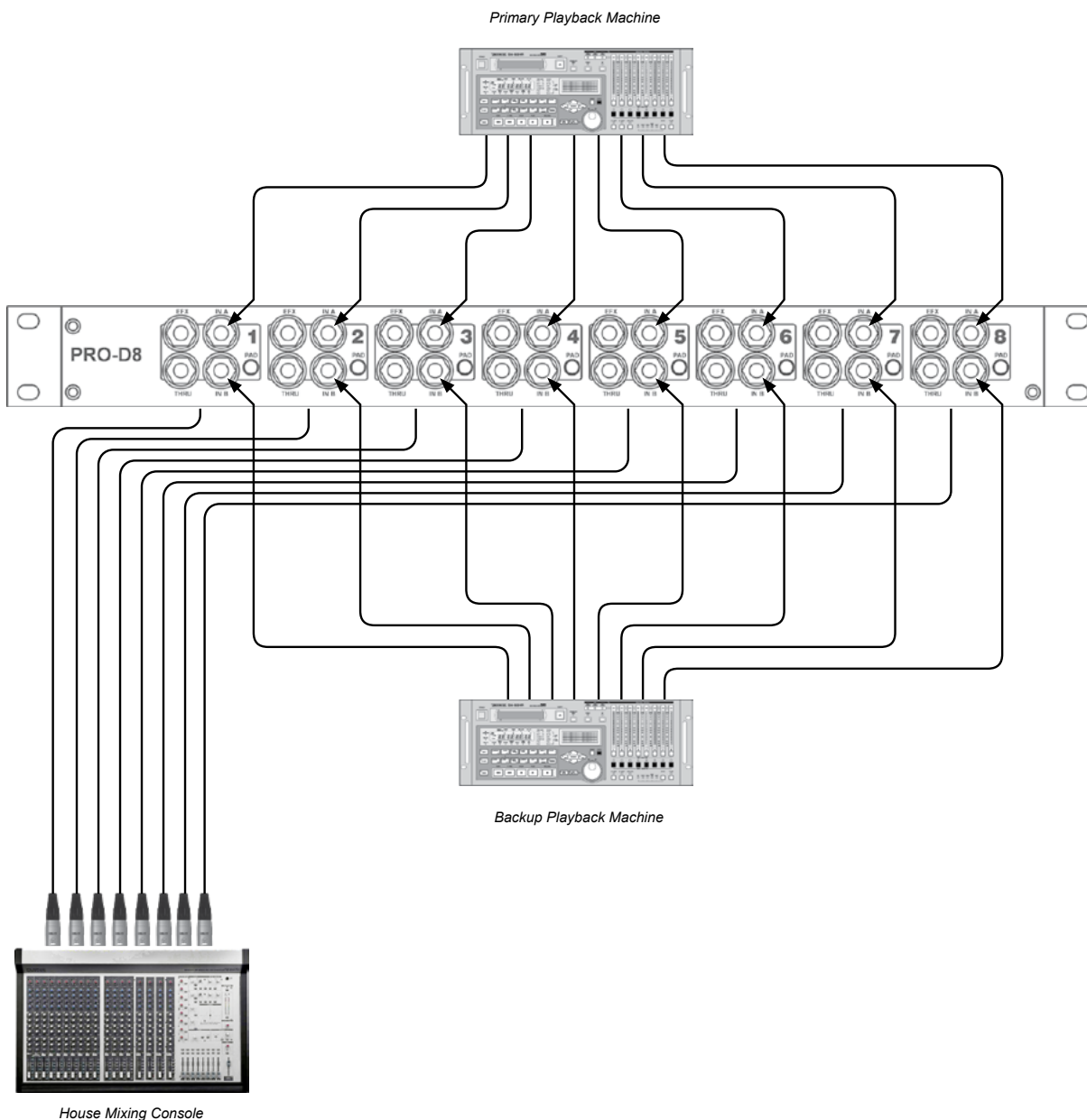

FAQ

Can I use the ProD8 with guitars or basses?

Yes of course you can, but keep in mind that the resistive mixer may apply a bit of a load on the instrument. This will not be noticeable with active (battery equipped) instruments like acoustic guitars, but you may notice a slight drop in level with low output instruments with passive pickups.

Can I use high output +4dB balanced sources with the ProD8?

Not really. The +4dB outputs could overload the transformers which could cause saturation. However, you can connect -10dB outputs to the ProD8 inputs with the -15dB PAD engaged without overloading the transformer.

I heard transformer saturation can sound good?

True, especially with very dynamic keyboards like a digital piano. All transformers will saturate at some point causing distortion. Some transformers will sound good when they begin to saturate and this is often cited as the type of analogue character that vintage gear can add to the sound. Radial transformers exhibit the warm Bessel curve with naturally cascading even harmonics that produces a musical distortion which is pleasant to the ear. If this is not what you want, engage the -15dB PAD to prevent saturation with high output sources.

Will the Radial ProD8 get rid of the buzz and hum I get in certain clubs?

Most buzz and hum problems are caused by stray AC current running through one piece of gear into another through the signal ground. This is exacerbated by less than ideal AC systems and varying ground reference voltages that are floating around. Transformer isolation can often eliminate these problems and eliminate noise.

Can I use the ProD8 backwards like a re-amp?

You could but the resistive mixer may cause a level to shift making it difficult to get the best tone. You would be further ahead to purchase a product like the Radial X-Amp for re-amping which this is specifically designed for this task.

Can I use the ProD8 as a splitter by sending the thru-put of channel-1 into channel-2?

Yes. Although this is an uncommon way to do things, it will work. Keep in mind that when you split the signal, you may have to adjust your levels to suit.

Can I use the ProD8 to isolate one mixer from another to help eliminate noise?

Yes, but be careful. Make sure the -15dB Pad is activated and listen for distortion. Your mixer output will likely be much louder than a keyboard or guitar and therefore you could overload the ProD8 transformer. Also, you will then have to send the ProD8 outputs to the mic-pre inputs on the second mixer as the proD8 outputs are mic level (not line level). This means that you will be using multiple buffers which could add some hiss or system noise. Note that Radial produces the Twin-ISO which is specifically designed for line-level isolation applications.

When driving two channels into one, can the Merge function cause phase cancellation?

Not likely. A simple Y-jack input can cause phase cancellation but seeing as we are employing a passive resistive mixer, this problem should not occur. If you do hear some phase cancellation, check to make sure the source is in phase.

Why are DIs always mic level out?

Because in concert sound systems, the stage is filled with microphones and direct boxes and these signals must share the same mic splitters, snake systems and mixing console inputs. By rendering all of the signals so that they are all similar in level, problems such as cross talk are reduced, overloading of the splitter is less problematic and system management becomes easier.

**RADIAL ENGINEERING
3 YEAR TRANSFERABLE WARRANTY**

RADIAL ENGINEERING LTD. ("Radial") warrants this product to be free from defects in material and workmanship and will remedy any such defects free of charge according to the terms of this warranty. Radial will repair or replace (at its option) any defective component(s) of this product (excluding batteries, finish and wear and tear on components under normal use) for a period of three (3) years from the original date of purchase. In the event that a particular product is no longer available, Radial reserves the right to replace the product with a similar product of equal or greater value. To make a request or claim under this limited warranty, the product must be returned prepaid in the original shipping container (or equivalent) to Radial or to an authorized Radial repair center and you must assume the risk of loss or damage. A copy of the original invoice showing date of purchase and the dealer name must accompany any request for work to be performed under this limited warranty. This limited warranty shall not apply if the product has been damaged due to abuse, misuse, misapplication, accident or as a result of service or modification by any other than an authorized Radial repair center.

THERE ARE NO EXPRESSED WARRANTIES OTHER THAN THOSE ON THE FACE HEREOF AND DESCRIBED ABOVE. NO WARRANTIES WHETHER EXPRESSED OR IMPLIED, INCLUDING BUT NOT LIMITED TO, ANY IMPLIED WARRANTIES OF MERCHANTABILITY OR FITNESS FOR A PARTICULAR PURPOSE SHALL EXTEND BEYOND THE RESPECTIVE WARRANTY PERIOD DESCRIBED ABOVE OF THREE YEARS. RADIAL SHALL NOT BE RESPONSIBLE OR LIABLE FOR ANY SPECIAL, INCIDENTAL OR CONSEQUENTIAL DAMAGES OR LOSS ARISING FROM THE USE OF THIS PRODUCT. THIS WARRANTY GIVES YOU SPECIFIC LEGAL RIGHTS, AND YOU MAY ALSO HAVE OTHER RIGHTS, WHICH MAY VARY DEPENDING ON WHERE YOU LIVE AND WHERE THE PRODUCT WAS PURCHASED.



www.radialeng.com

Radial Engineering Ltd.
1845 Kingsway Ave. Port Coquitlam, BC V3C 0H3, Canada
Tel: 604-942-1001 • Fax: 604-942-101 • Email: info@radialeng.com

www.radialeng.com