

Workhorse SixPack

500 Series Rack



User Guide

www.radialeng.com

Radial Engineering Ltd.
1845 Kingsway Ave., Port Coquitlam, BC V3C 0H3, Canada
tel: 604-942-1001 • fax: 604-942-1010
email: info@radialeng.com

IMPORTANT SAFETY & USER NOTICE



FOR PROFESSIONAL USE ONLY



Radial 500 series power racks are specifically designed for use by qualified professional audio engineers. The open frame design is not intended for use by consumers or those unfamiliar with this format. Even though the current and voltage levels are relatively low, we recommend that all slots be filled with a module or covers be placed over unfilled slots. This will help protect you from electrical shock.

These power racks are designed to be used with 500 series modules manufactured by Radial or others that follow the 500 series format. Even though there is no formalized standard, Radial has endeavored to take every step possible to ensure cross-brand compatibility. To this end, Radial has produced a free PDF download called the Workhorse Open Source Document (Whos.Doc) that outlines the mechanical and electrical requirements for module designs. Manufacturers are invited to consult this document in order to assist in assuring cross-platform compatibility with both current and older 500 series formats. Users should also consult this document and ensure the module being used follows the prescribed pin-out configuration.

The user should ensure that the module current requirements do not exceed the available current provided by the power rack. It is also important that when securing the module to the frame that the retainer screws not be over tightened or cross threaded. This will prevent damaging the threads and ensure a longer rack life.

Finally, hot swapping or exchanging modules when power is on can shorten the life of the card-edge connector. Although Radial has incorporated extra safety measures, hot swapping is not recommended. Damage caused by hot swapping is not covered under the Radial Limited Warranty. The user is responsible for any damage to the racks or modules arising out of hot swapping and the user shall save Radial Engineering Ltd. harmless should any damage occur. Please consult the Radial Limited Warranty for further details.

Radial® Workhorse SixPack

500 Series Power Rack

Table of Contents	Page
Feature set overview	1
Introduction and basic functions	3
Feed and Link Functions	4
D-sub and Omniport	5
Power supply capacity	6
Sliding modules in and out	7
Signal flow and levels	8
Basic XLR, TRS and D-sub connections	9
Setting up a channel strip	10
Using the front inputs	11
D-sub channels 7 and 8	11
Specifications	12
Radial Limited Warranty	Back Cover

Congratulations and thank you for purchasing the Radial Workhorse SixPack, an innovative six slot power rack designed for the 500 series modular format. This guide describes how to install modules safely and maximize the use of the SixPack features. We recommend that you sit back, have a coffee and take a few minutes to read it to familiarize yourself with the many innovative features that are built in.

To make this guide as easy to understand as possible, we have divided it into several sections. It begins with an overview, then descriptions of each function, ending with some real world applications. Should you find yourself asking a question that is not addressed, we invite you to view the SixPack FAQ page on our web site. This is where we post the latest hints and of course questions from users. If you still do not find what you are looking for, feel free to send an email to info@radialeng.com and we will do our best to answer your question in short order.

FEATURE SET

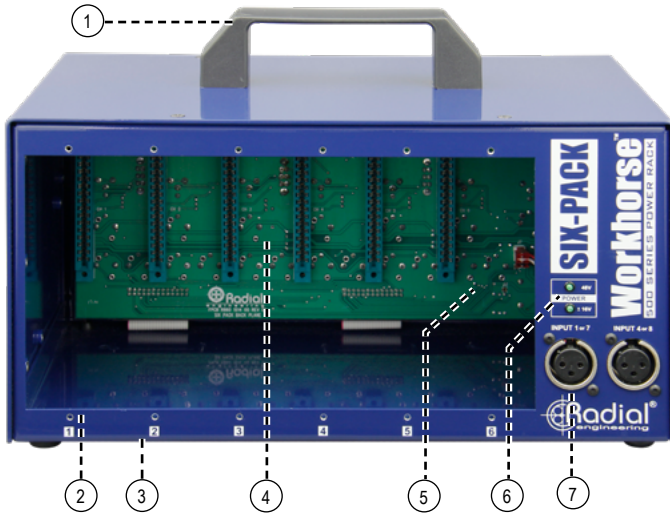

1. **REMOVABLE HANDLE:** Can be mounted on the top or side. Makes transporting the SixPack around the studio more convenient.
2. **6 SLOT RACK:** Compatible with Radial and all other 500 series modules.
3. **SOLID STEEL:** 'Road ready' 14-gauge steel construction for durability and improved shielding against stray magnetic fields.
4. **DOUBLE-SIDED PCB:** Military grade circuit board with through-hole parts soldered on both sides for durability. Full ground plane to reduce noise.
5. **SAFETY CIRCUITS:** Protects the SixPack and adjacent slots from shorts if a faulty module is inserted.
6. **POWER LED's:** Indicators provide visual status for +/-16 volt rail voltage and 48 volt phantom power.
7. **XLR INPUTS 7 & 8:** Convenient front panel XLR inputs let you connect mics and audio processors to modules 1 and 4 or route to channels 7 and 8 on the D-sub output.



8. **1600 MILLIAMPS SUPPLY:** Provides 265mA of average current per slot, plenty to be shared between modules. Perfect for high current tube devices!
9. **GROUND LUG:** Chassis grounding lug for studios with sophisticated grounding schemes.

CARD-SLOTS INPUTS & OUTPUTS

10. XLR INPUT/OUTPUT: XLR connectors are durable glass-filled nylon and bolted to the 14-gauge steel panel for durability. Large channel ID numbers on each slot make patching quick & easy.
11. TRS INPUT/OUTPUT: Balanced 1/4" TRS jacks are wired in parallel with XLRs and used to cross-patch modules.
12. D-SUB INPUT/OUTPUT: Eight channel interface connects the module inputs and outputs to your workstation. Uses industry standard DB-25 pin-out for balanced audio.
13. OMNIPOINT: 1/4" TRS changes function depending on the module installed, as determined by the manufacturer.
14. LINK: Combines stereo-ready modules together by sliding the LINK switch into the up position.
15. FEED: Sends the output from one module to the input of the next, eliminating the need for patch cables.

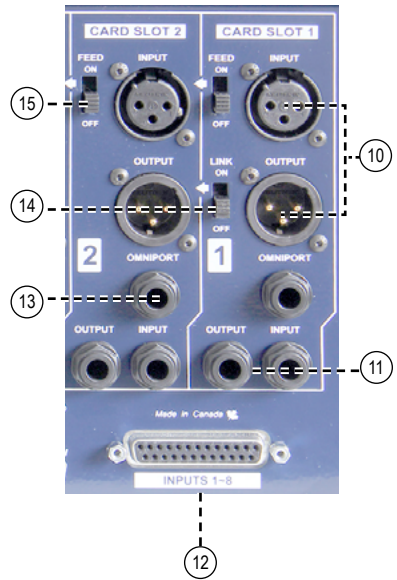

CHANNELS 7 & 8 FEATURE SET

16. FRONT XLR ASSIGN - 1/7 AND 4/8: Routes the front panel XLR inputs to the D-sub output or to card-slots 1 and 4.
17. MALE/FEMALE SWITCH (M/F): Routes the front panel XLR inputs to either the male XLR outputs or the D-sub output channels 7 and 8.
18. FEMALE XLR JACKS 7 & 8: Connects to D-sub channels 7 and 8 at the DB25 output. Used to send signal to a workstation via the D-sub interface.
19. MALE XLR JACKS 7 & 8: The front panel inputs for channels 7 and 8 can be routed to these XLR outputs to conveniently patch equipment from the rear panel.
20. TRS OUTPUTS 7 & 8: Balanced 1/4" TRS jacks are wired to the D-sub input channels 7 and 8. Used to receive signals originating from your audio workstation.

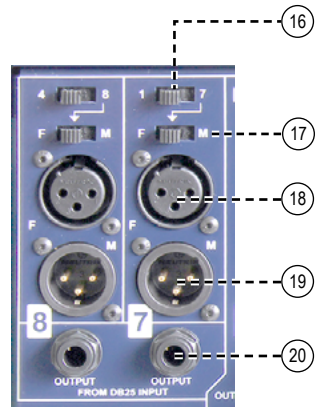

INTRODUCTION

The SixPack is a 6 slot power rack designed for 500 series modules. It provides power to the modules plus 48 volt phantom for mic preamps. Up to six modules may be used at any one time. Radial modules and those that have been designed by other manufacturers to take advantage of the Workhorse's extra features will enjoy the added functionality of the Omniport.

CARD SLOT I/O CONNECTIONS

Each of the SixPack card slots is equipped with XLR, D-Sub and 1/4" TRS inputs and outputs. The input sensitivity is dependant on the type of module being used. For instance if you are using a microphone preamplifier, the input will of course be suited for a low level microphone. If you are using a dynamic processor like a limiter or an EQ, then the input will usually be set to handle a professional +4dB balanced line-level signal.

Following 500 series convention, the XLR, TRS and D-sub outputs usually produce a +4dB balanced line level signal that is able to feed a professional recording system or line level mixing console. Put simply, the input level is determined by the type of module being used while the output level will typically be a balanced +4dB line level signal.

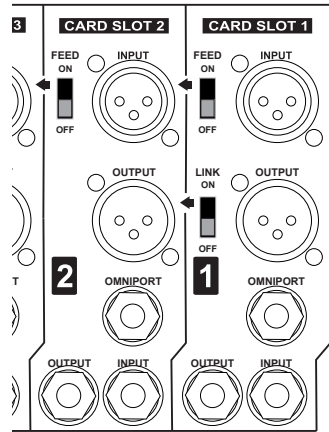

BASIC SIGNAL FLOW

This flow chart shows the basic signal routing for slots one through six. The signal comes into the SixPack via the rear panel female XLR, 1/4" TRS or D-Sub inputs and is routed to the module via the 15-pin card-edge receptacle. Once the signal is processed by the module, the signal is output via the male XLR, 1/4" TRS or D-Sub outputs.

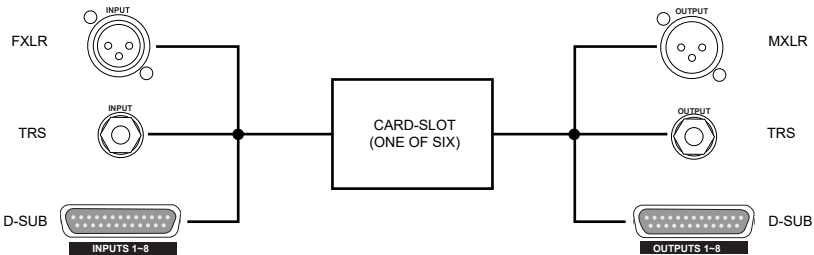

FEED SWITCH

With older 500 series racks, connections between modules were done using an XLR patch cable whereby the output from one module would plug into the input of another. The SixPack simplifies the process by introducing a FEED switch on each card-slot. This switch connects the balanced output of one module into the adjacent module, eliminating the need for patch cables.

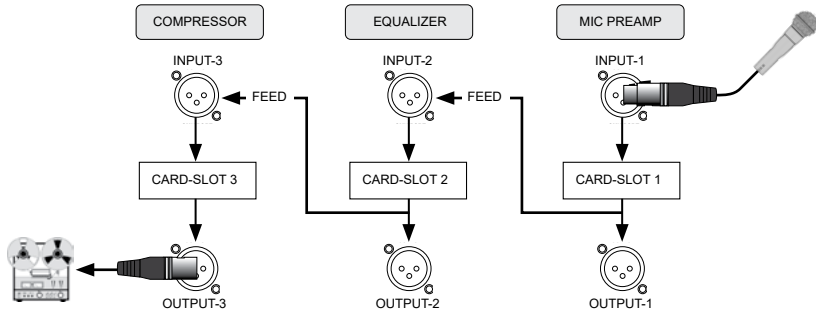

The FEED switch lets you daisy chain a series of adjacent modules to create a customized channel strip whereby a mic preamp feeds an EQ, which in turn could feed a compressor. Changing the order is simply a matter of relocating the modules or patching using an XLR or TRS cable.

STEREO LINK SWITCH

Odd numbered card-slots are equipped with a LINK switch that allows modules that are 'stereo ready' to be linked together. A typical example would be using two limiters on a stereo track where you want the dynamics to be the same for both channels.

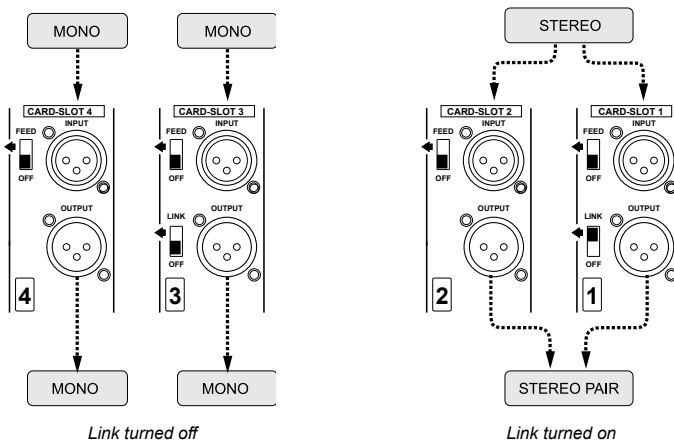

OMNIPORT

Omniport is a special ¼" TRS jack located on the rear panel that has been left 'open' to allow the module to perform a unique task. In other words, depending on the type of module, the manufacturer can assign the Omniport to perform a function that may be most appropriate. This could be a key input on a gate, a TRS effects loop or maybe an output. As the Omniport function is determined by the module, you will need to consult the module manufacturer's specification for details on how it was designed to be used.

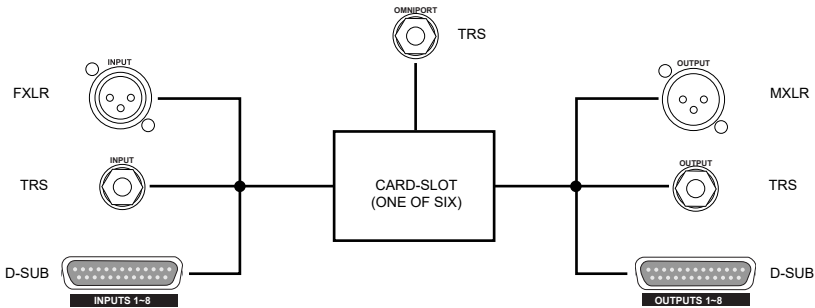

Radial Modules Omniport Assignment:

<i>Module</i>	<i>Omniport function</i>
PowerPre:	Instrument input
JDV-Pre:	Line level output
PowerTube:	Instrument input
PreComp:	Send & receive insert
PreMax:	Instrument input
X-Amp:	Instrument input
PhazeQ:	Balanced dry signal out
JDX:	Direct box output

<i>Module</i>	<i>Omniport function</i>
EXTC:	Send & receive insert
Komit:	Compressor side chain
Shuttle:	Extra insert loop
Q3:	Send & receive insert
Q4:	Unbalanced I/O
TankDriver:	Alternate reverb out
TossOver:	Alternate 2-way output
SubMix:	Mixer expansion bus
ChainDrive:	Unbalanced input

D-SUB INTERFACE AND THE FRONT PANEL CONVENIENCE XLRs

The SixPack is equipped with two 8-channel D-sub connectors that let you route signals between your workstation and the SixPack. D-sub channels 1 thru 6 are routed to the card-slots inputs and outputs while D-sub channels 7 and 8 are routed to convenience jacks on the front and rear panels. These allow you to patch external processors into your workstation via the SixPack. Switches on the rear panel let you to choose how the connectors are routed. The routing options are:

Front XLR	To	Card-slots 1 & 4
Front XLR	To	D-Sub ch. 7 & 8
Front XLR	To	Rear Male XLR



UNPACKING THE SIXPACK

It is recommended that you save all packaging. Inside you will find the power supply, power cable suitable for your region and a handle. The handle may be attached to the side or the top using two screws and two washers as shown below.

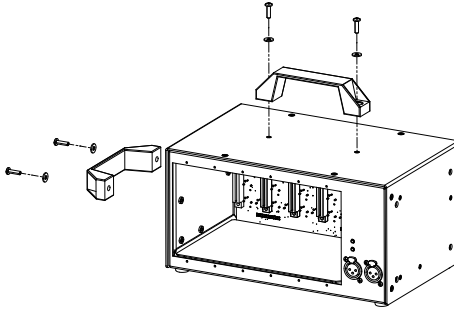

POWERING THE SIXPACK

The SixPack employs an external 100V to 240V power supply that automatically converts the various voltages used around the world and regulates them before sending the power to the SixPack. A standard male IEC/EIN power input connector makes it easy to travel as you will only need to change the cable to suit the local power connector type. The connection between the power supply and the SixPack is a 5-pin locking XLR.

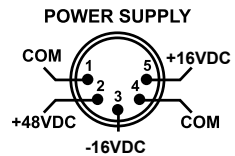

There is no power switch on the SixPack. As soon as you connect the power supply to the SixPack, a front panel LED will illuminate to let you know the power supply is active. This indicates the +16/-16V rails are ready.

PHANTOM POWER

A second LED indicator will illuminate to tell you that 48V phantom is present. Phantom power is only sent to the modules when the supply connection to the 15-pin card slot is made. This will normally only be found on preamp modules that employ 48V phantom. Other modules will not be affected and will simply ignore the phantom power as if it were not there.

POWER SHARING

The power supply produces 1600 milliamps (mA) of current that is shared between the card-slots. So for instance, if you have power-hungry tube preamps in slots 1 thru 4 that require 250 milliamps of current each, you still have 600 milliamps of current left to power the other card-slots. Considering most 500 series modules use between 40 and 130 milliamps of current, it is unlikely you will ever exceed the SixPack's available power.

Example:	Slot-1	Radial PowerTube tube preamp	235mA
	Slot-2	Radial PowerTube tube preamp	235mA
	Slot-3	Radial PowerTube tube preamp	235mA
	Slot-4	Radial PowerTube tube preamp	235mA
	Slot-5	Radial Komit compressor	130mA
	Slot-6	Radial Komit compressor	130mA
Total Current Draw:			1200mA (400mA to spare!)

INSTALLING MODULES IN THE SIXPACK

It's always safer to make electrical connections with the power disconnected. The SixPack's internal power circuit is equipped with protective measures intended to provide a margin of safety should a module exchange be performed with the power on. However, the SixPack is not designed to allow repeated insertion and removal of modules while the power supply is active. Always disconnect the power supply before exchanging modules.

Slide your modules into a slot until the 15-pin card-edge mates with the rear plane connector and push firmly. Once inserted, secure the module in place using the supplied Phillips 4/40 machine screws. To prevent damage to the frame do not over tighten the screws. After the module is inserted, it will automatically route the signal from the rear panel connectors to and from the module.

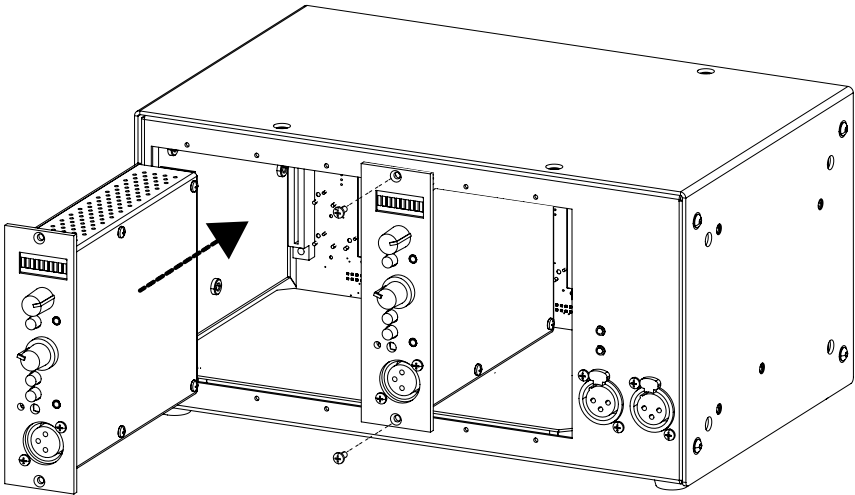

SIGNAL FLOW AND LEVELS

Because the SixPack is modular, it can accept a multitude of devices into its card slots. This also means that you need to understand the signal flow so that you can be sure what you want to do will work. In the world of audio, there are basically four 'low level' signal groups to contend with before you get to high power output levels such as those produced by power amplifiers to drive loudspeakers.

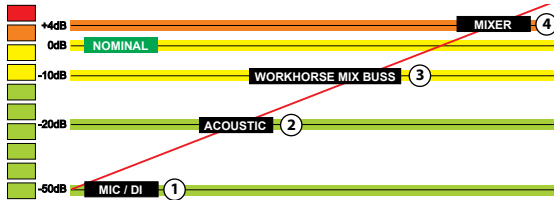

1. **MIC LEVEL RANGE:** Microphones and direct boxes produce the weakest signals. These typically range from -60dB to -40dB. Some such as ribbon microphones can be as low as -70dB while condenser mics will generally be at the top end of this range. With a SixPack, one would connect a microphone to a preamp like the PowerPre. This would elevate the mic-level signal to produce a +4dB line-level signal at the XLR output.
2. **INSTRUMENT LEVEL RANGE:** The output levels produced by instruments can range widely. A single coil electric bass guitar can produce as little as -40dB while an electronic keyboard, sampler or digital piano is capable of producing -10dB or more. For low level instruments, 500 series modules like the JDV™ amplify the signal to produce a +4dB signal level at the XLR output for direct recording.
3. **UNBALANCED -10dB LINE LEVEL RANGE:** Unbalanced outputs from CD players, keyboards, mixers and home hi-fi components are usually specified at -10dB and are often referred to as consumer line-level. These normally connect to a preamp input or a line level module. If too loud, one simply engages a pad.
4. **BALANCED +4dB LINE LEVEL RANGE:** This is the professional line level that comes from a recording system and is normally the level that connects in and out of EQs, compressors and so on. Most 500 series modules receive and produce a +4dB signal level.

Matching the output level of one device to the input of the next will help you avoid distortion and maximize signal-to-noise. For instance, using a +4dB output to drive a -10dB input could overload the input and cause distortion. Conversely, a -10dB output may not have enough gain to drive the input of a +4dB device resulting in a higher noise floor.

Because each of the SixPack slots is equipped with both XLR and ¼" TRS balanced input and output connectors, you are pretty much free to interconnect modules or route signals to other devices as you like. Once you start working with the SixPack, you will quickly come to understand all of the capabilities and how easy it is to use.

MAKING CONNECTIONS

As a precaution, **turn down levels** before making connections. This will avoid the loud on-off transient that can damage equipment or blow speakers. After you have some modules installed you can connect the 5-pin XLR power supply cable. The SixPack will instantly power on and the front panel LED indicators will illuminate.

XLR and TRS connections

Connecting to and from modules is done using the XLR, ¼" TRS and D-sub connectors. These jacks are wired in parallel. The ¼" TRS connectors are particularly useful for cross-patching between modules, like a patchbay, opening many options for creative signal processing.

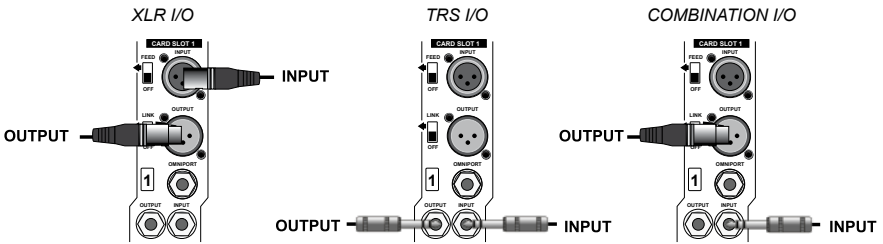

D-sub connections for modules

The SixPack is equipped with D-sub input and output connectors wired to the TASCAM™ pin-out standard for easy patching to workstations. These carry 8 channels of audio back and forth between your workstation and the SixPack. Once connected, D-sub channels 1 thru 6 are automatically routed to the six card-slot inputs and outputs. D-sub channels 7 and 8 are routed to the ¼" TRS and female XLR convenience jacks on the front and rear panels.

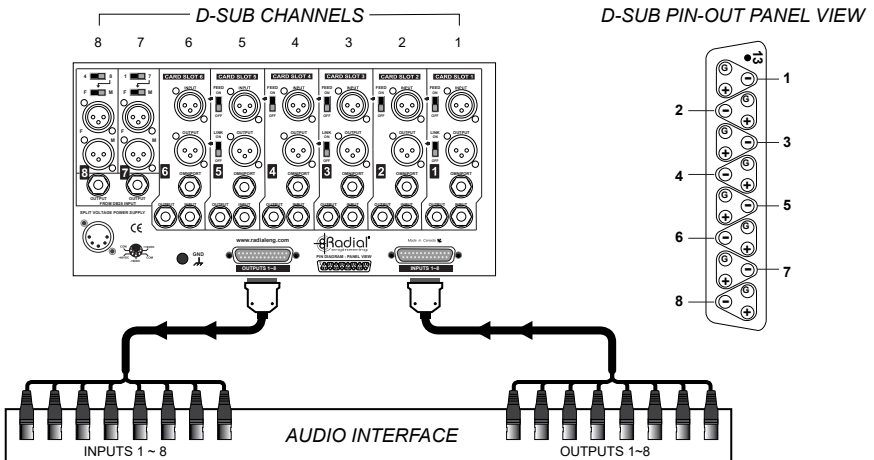

SETTING UP A CHANNEL STRIP

The SixPack makes it easy to combine several modules together to create a channel strip. For instance, when recording a vocal track, you may want to run a mic preamp into an EQ which in turn would connect to the limiter. The direct XLR output from the limiter would then be sent to the recording system.

Using the old system, you would connect the microphone to the mic preamp using a standard XLR cable. The mic preamp output would then connect to the EQ which in turn would connect to the limiter. The direct XLR output from the limiter would then be sent to the recording system.

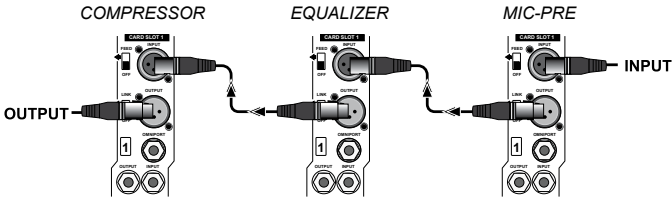

The SixPack simplifies the process with a FEED switch that replaces inter-module patch cables. Instead of using an XLR cable, you simply push the FEED switch into the UP position and it routes the signal to the adjoining module's input working from left to right (front view). Because the FEED function is tied to the XLR connector, it will work with both Radial modules and older 500 series modules.

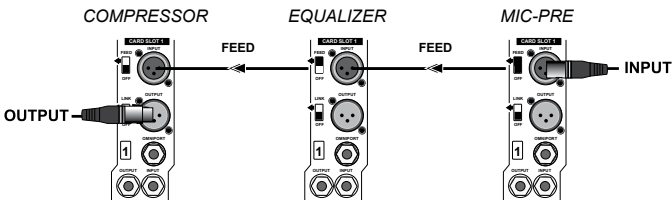

Once you get started, you will soon find all kinds of new and exciting ways to patch modules. You could, for instance, use the FEED switch to connect one module into the next while using a TRS cable to simultaneously patch the signal to a third module.

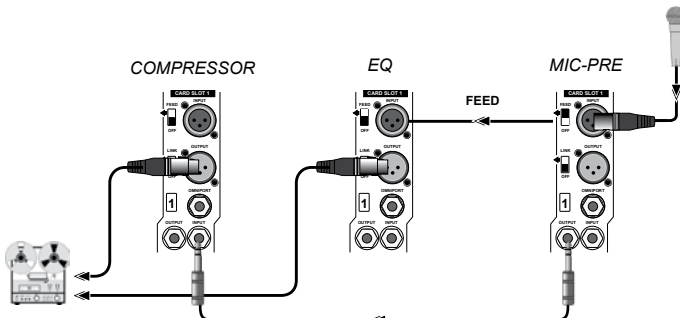

USING THE CONVENIENCE XLR INPUT JACKS

The front female XLR inputs can be used in several ways depending on how the rear panel switches for channels 7 and 8 are set.

Routing the front inputs to modules 1 & 4

The SixPack makes it easy to set up a stereo channel strip by routing the front channel 7 and 8 convenience jack to slots 1 and 4. This lets you add an EQ to slots 2 and 5 and a compressor to slots 3 and 6 to create a stereo 'strip of dreams'. The outputs of the modules can be connected to the workstation using the XLR, TRS or D-sub connectors.

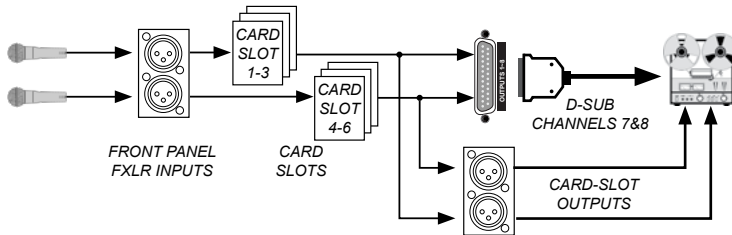
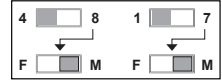

Routing the front inputs to rear outputs

You can also choose to route the front female XLR inputs to male XLR outputs on the rear panel. This option lets you patch into a preamp or processor without having to reach around to the back panel. Set the rear panel switches as shown to route the front XLR inputs to the rear XLR outputs.

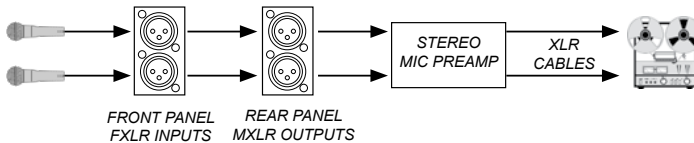
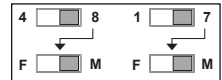

Routing the front inputs to D-sub channels 7 & 8

You can route the front inputs to D-sub channels 7 and 8 and patch the output of a mic or preamp to your workstation. Set the rear panel switches as shown to route the front inputs to the D-sub interface. This setup can be used while recording to connect two additional microphone signals along with the modules in the six card-slots.

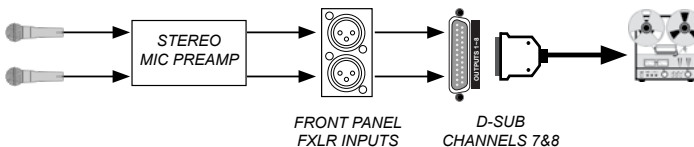
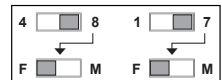

WORKHORSE SIXPACK SPECIFICATIONS

- Circuit type:.....Connection bus from modules to connectors
- Format:Desktop
- Number of slots:6
- Input connectors:8 balanced XLR male, 8 ¼" TRS, 25-Pin D-Sub
- Output connectors:8 balanced XLR female, 8 ¼" TRS, 25-Pin D-Sub
- Compatibility:Adheres to the Whos-Doc and VPR Alliance
- Omniport:.....Yes
- Feed switch:Yes
- Stereo link:.....Yes
- 48V phantom power:Yes on all card-slots
- Available current:.....1600 milliamps
- Average current:266 mA per slot
- Card slot impedance:.....Module dependent
- Ground connections:Chassis
- XLR pin wiring:AES standard: pin-1 ground, pin-2 (+), pin-3 (-)
- D-sub pin-out:Follows Tascam D-sub standard
- Power supply:External 100V - 240V AC with 48V Phantom
- PSU Connection:Locking 5 pin XLR female on cable

WORKHORSE SIXPACK BLOCK DIAGRAM

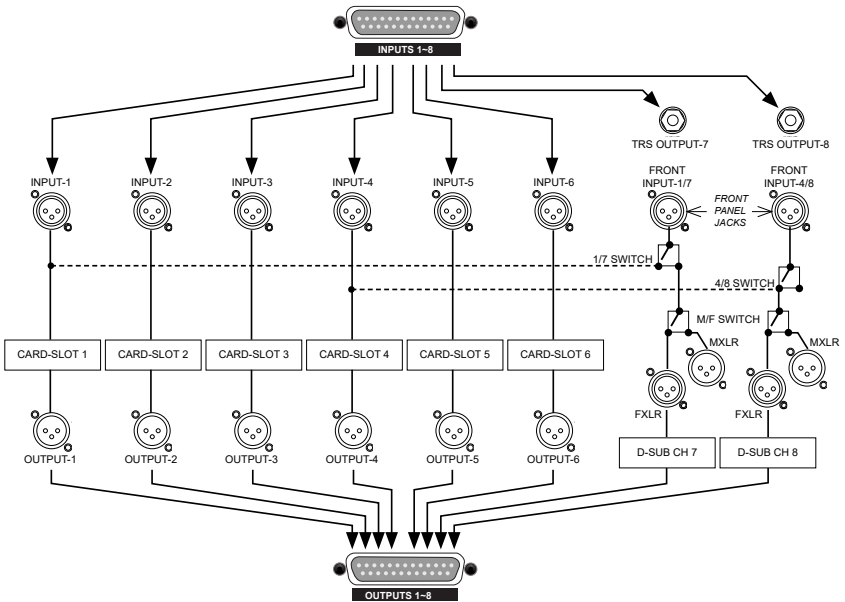

THREE YEAR TRANSFERABLE LIMITED WARRANTY

RADIAL ENGINEERING LTD. ("Radial") warrants this product to be free from defects in material and workmanship and will remedy any such defects free of charge according to the terms of this warranty. Radial will repair or replace (at its option) any defective component(s) of this product (excluding finish and wear and tear on components under normal use) for a period of three (3) years from the original date of purchase. In the event that a particular product is no longer available, Radial reserves the right to replace the product with a similar product of equal or greater value. In the unlikely event that a defect is uncovered, please call 604-942-1001 or email service@radialeng.com to obtain an RA number (Return Authorization number) before the 3 year warranty period expires. The product must be returned prepaid in the original shipping container (or equivalent) to Radial or to an authorized Radial repair center and you must assume the risk of loss or damage. A copy of the original invoice showing date of purchase and the dealer name must accompany any request for work to be performed under this limited and transferable warranty. This warranty shall not apply if the product has been damaged due to abuse, misuse, misapplication, accident or as a result of service or modification by any other than an authorized Radial repair center.

THERE ARE NO EXPRESSED WARRANTIES OTHER THAN THOSE ON THE FACE HEREOF AND DESCRIBED ABOVE. NO WARRANTIES WHETHER EXPRESSED OR IMPLIED, INCLUDING BUT NOT LIMITED TO, ANY IMPLIED WARRANTIES OF MERCHANTABILITY OR FITNESS FOR A PARTICULAR PURPOSE SHALL EXTEND BEYOND THE RESPECTIVE WARRANTY PERIOD DESCRIBED ABOVE OF THREE YEARS. RADIAL SHALL NOT BE RESPONSIBLE OR LIABLE FOR ANY SPECIAL, INCIDENTAL OR CONSEQUENTIAL DAMAGES OR LOSS ARISING FROM THE USE OF THIS PRODUCT. THIS WARRANTY GIVES YOU SPECIFIC LEGAL RIGHTS, AND YOU MAY ALSO HAVE OTHER RIGHTS, WHICH MAY VARY DEPENDING ON WHERE YOU LIVE AND WHERE THE PRODUCT WAS PURCHASED.



www.radialeng.com

Radial Engineering Ltd.

1845 Kingsway Ave., Port Coquitlam, BC V3C 0H3, Canada

tel: 604-942-1001 • fax: 604-942-1010

info@radialeng.com • www.radialeng.com

