

SAT-2 User Guide



Radial Engineering Ltd.
1845 Kingsway Ave., Port Coquitlam, BC V3C 0H3, Canada
Tel: 604-942-1001 • Fax: 604-942-1010 • Email: info@radialeng.com

SAT-2 Stereo Audio Attenuator & Monitor Controller

Overview.....	1
Features	2
Making Connections.....	3
Setting Levels.....	3
Mute, Mono and Dim	4
Block Diagram.....	5
Specifications	6
Warranty	Back Cover



Thank you for purchasing the SAT-2, a simple but robust audio attenuator and monitor controller. While the SAT-2 has an intuitive feature set that is designed to be easy to use, please take a few minutes to review this short manual to get the most out of this deceptively powerful device. If you find you have any questions not answered here, please visit our website at www.radialeng.com where we post frequently asked questions and product updates. If you still don't find the answer to your question, feel free to send us an email at info@radialeng.com and we will do our best to respond promptly.

OVERVIEW

The SAT-2 gives you the ability to set your levels or attenuate hot signals wherever you might need to. It works as a monitor controller between an audio interface and a set of powered speakers, or to attenuate the output of a recording console before the signal is sent to a recording device. The SAT-2 can also be connected between line-level studio devices, taming the outputs of a hot microphone preamp to avoid overloading the inputs of a recording interface without losing any tone or character. With its compact and rugged design and useful feature set, the SAT-2 makes for a great addition to your audio tool kit.

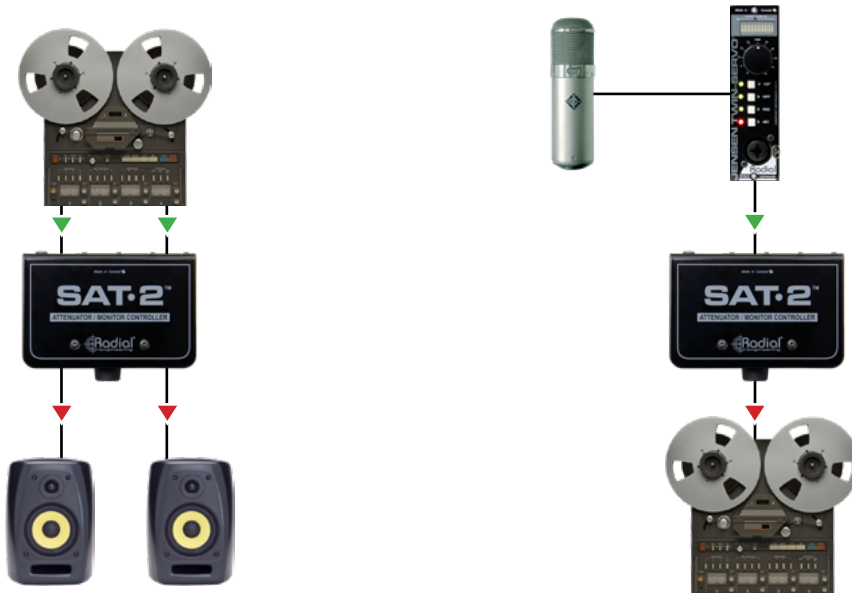

FEATURES

1. **MONO:** Sums the left and right outputs to mono.
2. **MUTE:** Silences the outputs of the SAT-2.
3. **MASTER LEVEL:** Sets the overall output level. Passes signal at unity gain (no attenuation) when turned fully clockwise.
4. **DIM ON:** Used to reduce output levels temporarily without affecting the setting on the master level control.
5. **DIM LEVEL:** Sets the amount of signal attenuation applied when Dim On is engaged.
6. **OUTPUTS:** XLR outputs for a pair of powered speakers or the inputs of a recording interface.
7. **INPUTS:** TRS ¼" or XLR inputs are available for the left and right channels.
8. **NO SLIP PAD:** Provides electrical & mechanical isolation and prevents the unit from sliding around.

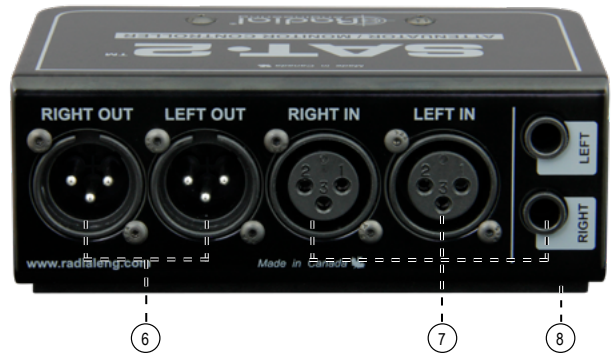
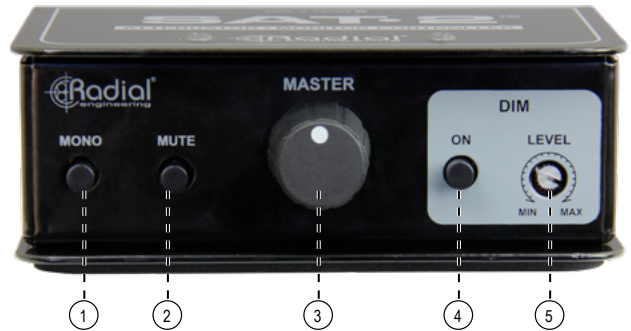

MAKING CONNECTIONS

Before plugging in any cables, ensure that your sound system is turned off and all volume levels are turned down. This prevents any plug-in transients from damaging speakers or other sensitive components. The SAT-2 is passive, so it does not require any power to operate.

Each input has a ¼" TRS and an XLR connector to accept balanced audio signals from a variety of different sources. For best results, only use one of these connector types at a time on each channel. The XLR outputs are designed to be connected to the line level inputs of a recording console, powered speaker, or audio interface.

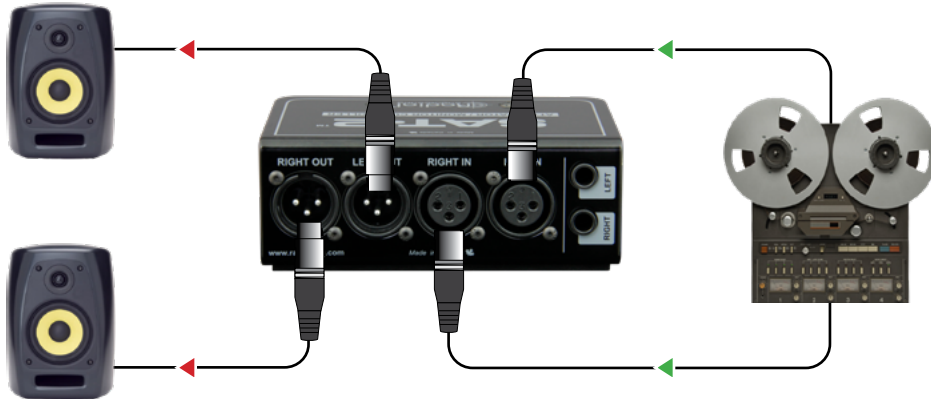

SETTING LEVELS

The SAT-2 is a unity gain device, which means that when the master level control is turned all the way up (fully clockwise) the SAT-2 outputs have the same signal level as its inputs. When first setting levels, start with the volume turned all the way down, and then slowly turn back up until you reach a comfortable listening level.

MONO, MUTE AND DIM

The MONO switch sums the left and right signals together at each of the outputs, allowing you to check for phase compatibility when mixing. You can also use it to take a mono input and split it to two destinations, or use it for parallel processing of a mono signal.

The MUTE switch cuts the signal to the XLR outputs, while the DIM switch allows you to temporarily reduce the output level without changing the position of the master level control. The DIM LEVEL sets the amount of attenuation provided when the DIM switch is depressed. Use the DIM to check your mixes at lower volume levels, or to talk to other people in the control room without stopping audio playback.

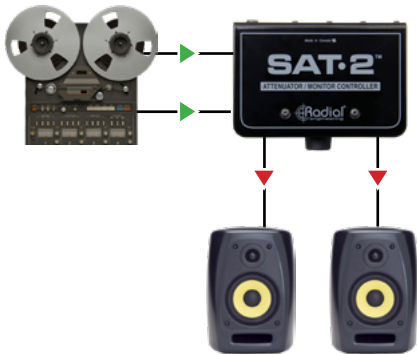

Monitor Controller

Connect between your audio interface and powered speakers, utilizing the level control and mono switch to check phase compatibility.

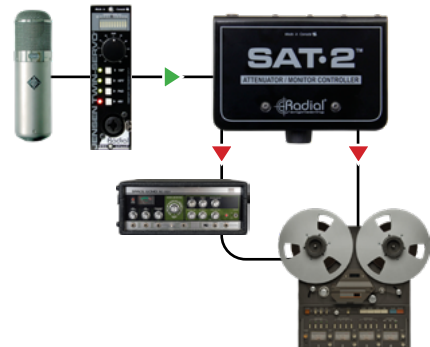

Parallel Processing

Take the output of a mic preamp into the SAT-2, engage the mono switch, and connect one of the SAT-2 outputs directly to your recording interface, and the other to an effects device.

BLOCK DIAGRAM*

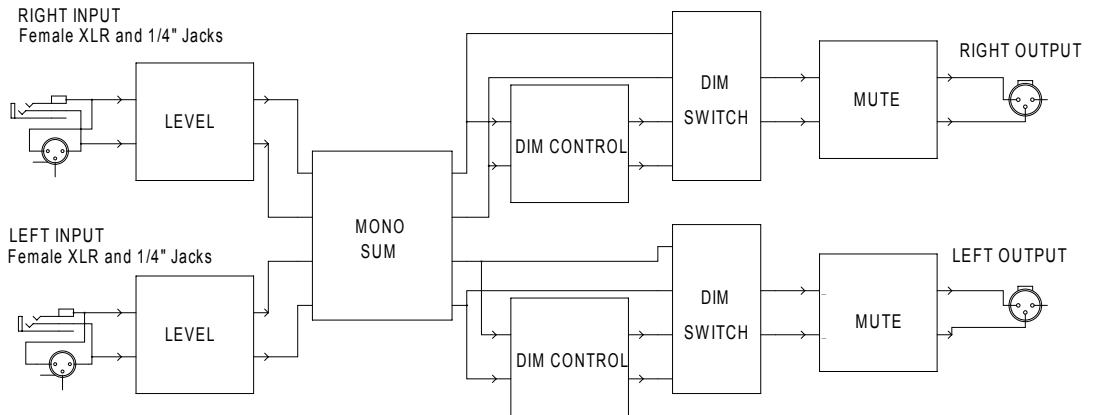

* Subject to change without notice.

SPECIFICATIONS*

Audio Circuit Type:	Passive Audio Signal Path
Number of Channels:	2
Frequency Response:	20Hz-20kHz
Noise Floor:	-115dBu
Dynamic Range:	>141dBu
Maximum Input:	>+26dBu
Gain:	0dB
Intermodulation Distortion:	>0.001% @0dBu
Total Harmonic Distortion:	>0.0005% @ 0dBu
Common-Mode Rejection Ratio:	>80dB
Phase deviation:	0° @ 20Hz, 0° @ 1kHz, +2° @ 10kHz
Input Impedance:	8k Ohms
Output Impedance:	1.8k Ohms
Insertion Loss:	-0.73dBu
Power:	Passive, no power required
Construction:	14 gauge steel chassis & outer shell
Finish:	Durable Powder Coat
Size (L x W x D):	5"x3.312"x1.78"
Weight:	0.70kg (1.55lbs)
Conditions:	For use in dry conditions between 5°C and 40°C
Warranty:	Radial 3-Year, transferable

* Subject to change without notice.

RADIAL ENGINEERING 3 YEAR TRANSFERABLE WARRANTY

RADIAL ENGINEERING LTD. ("Radial") warrants this product to be free from defects in material and workmanship and will remedy any such defects free of charge according to the terms of this warranty. Radial will repair or replace (at its option) any defective component(s) of this product (excluding finish and wear and tear on components under normal use) for a period of three (3) years from the original date of purchase. In the event that a particular product is no longer available, Radial reserves the right to replace the product with a similar product of equal or greater value. In the unlikely event that a defect is uncovered, please call 604-942-1001 or email service@radialeng.com to obtain an RA number (Return Authorization number) before the 3 year warranty period expires. The product must be returned prepaid in the original shipping container (or equivalent) to Radial or to an authorized Radial repair center and you must assume the risk of loss or damage. A copy of the original invoice showing date of purchase and the dealer name must accompany any request for work to be performed under this limited and transferable warranty. This warranty shall not apply if the product has been damaged due to abuse, misuse, misapplication, accident or as a result of service or modification by any other than an authorized Radial repair center.

THERE ARE NO EXPRESSED WARRANTIES OTHER THAN THOSE ON THE FACE HEREOF AND DESCRIBED ABOVE. NO WARRANTIES WHETHER EXPRESSED OR IMPLIED, INCLUDING BUT NOT LIMITED TO, ANY IMPLIED WARRANTIES OF MERCHANTABILITY OR FITNESS FOR A PARTICULAR PURPOSE SHALL EXTEND BEYOND THE RESPECTIVE WARRANTY PERIOD DESCRIBED ABOVE OF THREE YEARS. RADIAL SHALL NOT BE RESPONSIBLE OR LIABLE FOR ANY SPECIAL, INCIDENTAL OR CONSEQUENTIAL DAMAGES OR LOSS ARISING FROM THE USE OF THIS PRODUCT. THIS WARRANTY GIVES YOU SPECIFIC LEGAL RIGHTS, AND YOU MAY ALSO HAVE OTHER RIGHTS, WHICH MAY VARY DEPENDING ON WHERE YOU LIVE AND WHERE THE PRODUCT WAS PURCHASED.



www.radialeng.com

Radial Engineering Ltd.
1845 Kingsway Ave., Port Coquitlam, BC V3C 0H3, Canada
Tel: 604-942-1001 • Fax: 604-942-1010 • Email: info@radialeng.com



Radial SAT-2 User Guide - Part #: R870 1037 00 / 04-2026 Copyright © 2018 All rights reserved.
Appearance and specifications subject to change without notice.

www.radialeng.com