

JX44 V2

Guitar & Amp Signal Manager



OWNER'S MANUAL

Radial Engineering Ltd.
1165-1845 Kingsway Ave, Port Coquitlam BC V3C 0H3
Tel: 604-942-1001 • www.radialeng.com
Email: info@radialeng.com

www.radialeng.com

Radial JX44 V2 Owner's Manual

Table of Contents

Overview.....	2
Features	3-4
The Instrument Inputs.....	5
The Amplifier Outputs.....	6
The Mute Switch.....	6
The Stereo EFX Loop.....	7
The EFX Loop Remote Input.....	8
The Tuner Output	9
The Direct Output	9
The SGI Loop	10-11
The JR-5 Remote	12-13
MIDI Capabilities	13-15
Specifications	16
Warranty.....	Back Cover

INTRODUCTION

Thank you for purchasing the JX44 V2, a guitar and amplifier signal manager that allows you to take control of even the most complex stage setups, with the ability to connect multiple instruments, amplifiers, effects devices, and remote footswitches simultaneously. The JX44 V2 allows for seamless signal routing on stage that helps enhance the performance while maintaining high-quality audio that meets the needs of professional worldwide concert touring.

We encourage you to read through this manual to familiarize yourself with the many features available on the JX44 V2, allowing you to get the most out of this powerful stage control device. If you have any questions not answered in this user guide, please visit our website at www.radialeng.com for additional resources and frequently asked questions.

OVERVIEW

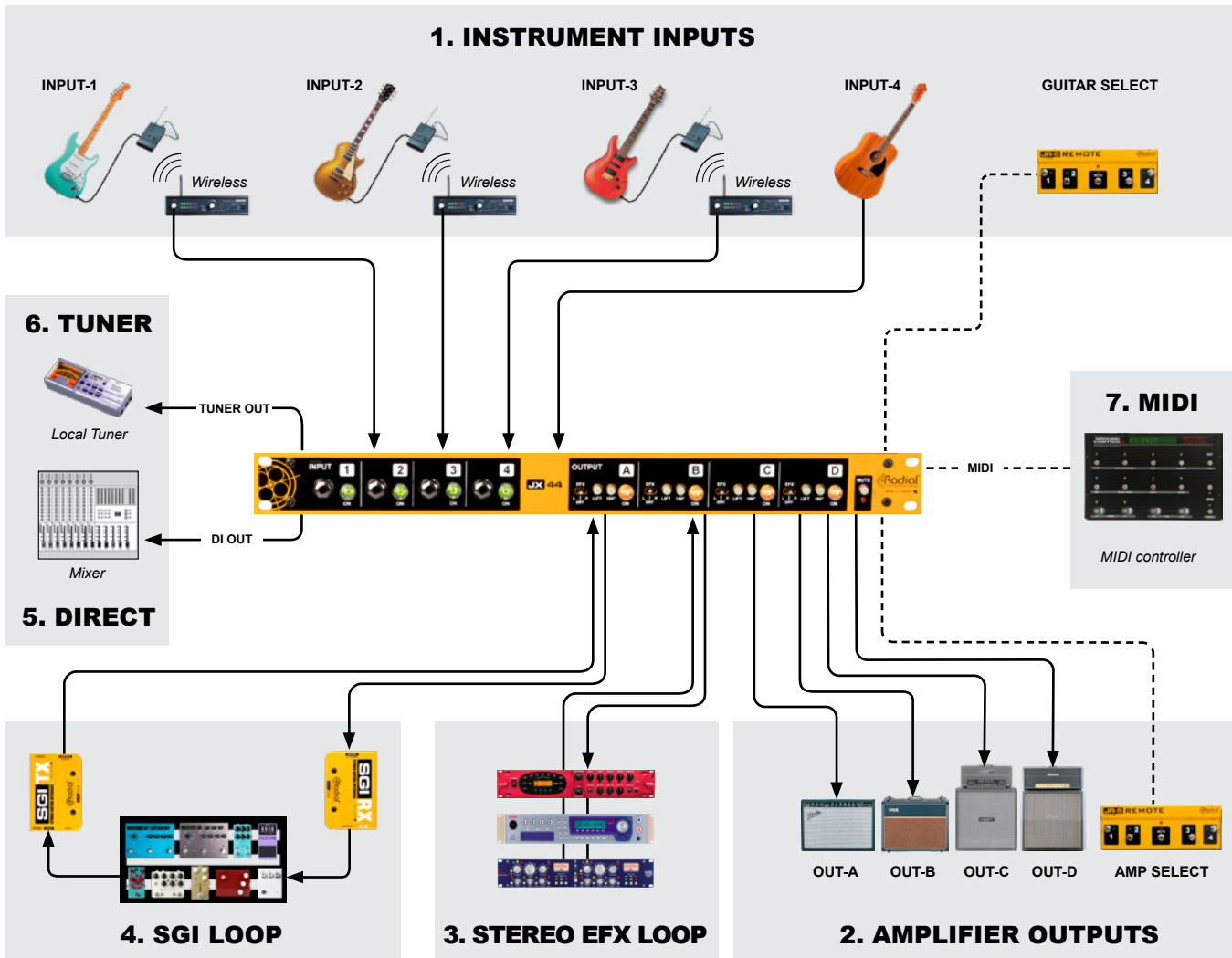

1. INSTRUMENT INPUTS: The JX44 starts with a four-input instrument selector for wired and wireless guitars. The JX44 can have all your instruments ready and waiting, and the optional JR-5 remote footswitch allows hands-free operation with LED indicators.

2. AMPLIFIER OUTPUTS: These four outputs allow you to connect multiple amplifiers at the same time or select between them as needed, while assigning EFX channels to individual amps to easily accommodate complex wet/dry/wet setups. A pristine Class-A signal path and Jensen transformers for isolation offer amazing sound quality while eliminating hum and buzz caused by ground loops.

3. STEREO EFX LOOP: Patch stereo rackmount effects and pedals into this local hi-impedance effects loop for use with all connected instruments. Each side of the Stereo EFX loop can be assigned individually to each amplifier output.

4. SGI LOOP: This balanced effects loop provides the option of utilizing the SGI TX/RX Instrument Line Driver System to connect your amps to a pedalboard over long cable runs up to 100 meters (300 feet) away without introducing noise or signal loss.

5. DIRECT OUTPUT: The built-in Radial direct output allows you to record the performance or feed signals from acoustic instruments straight to the FOH console. This output can be assigned before or after the EFX Loop or assigned exclusively to instrument Input-4.

6. TUNER OUTPUT: The Tuner Out is fed from all inactive instrument inputs, so a guitar tech can simply grab and tune without disrupting the performance.

7. MIDI INPUT: Built-in MIDI functionality allows you to use MIDI footswitches and controllers to use the functions of the JX44 remotely. Instrument and amplifier switching & muting, and EFX Loop on/off are all controllable via MIDI commands.

FRONT PANEL FEATURES

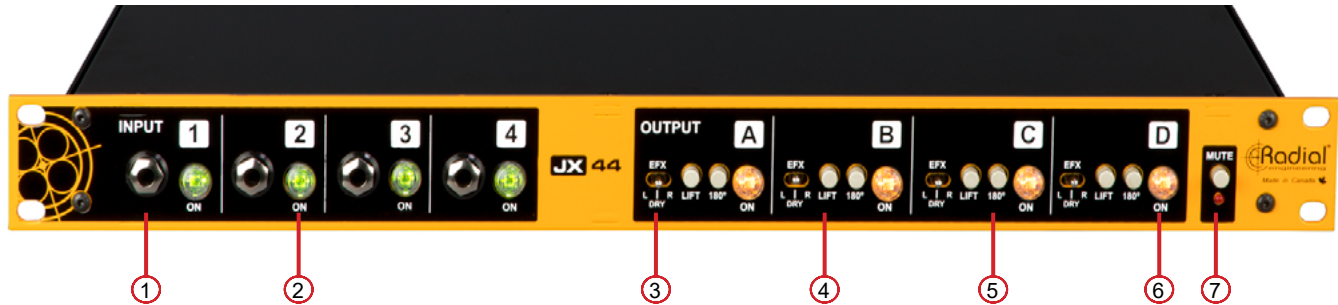

1. **INPUTS 1-4:** Buffered gold-contact inputs for unbalanced instruments such as guitars and basses. The front panel jacks take priority over the rear panel instrument inputs .
2. **INPUT ON/OFF:** Large switches with green LED indicators turn each instrument input on/off. Multiple inputs can be on simultaneously.
3. **EFX ASSIGN:** Selects whether the left or right EFX Loop returns feed the corresponding amplifier output. When 'dry' is selected, the EFX Loop will not feed the amp output.
4. **180°:** Reverses signal polarity at the corresponding amplifier output to help correct phase issues when using multiple amps simultaneously.
5. **LIFT:** Disconnects chassis ground on the corresponding amplifier output to eliminate hum and buzz caused by ground loops.
6. **OUTPUT ON/OFF:** Large switches with amber LED indicators turn each amplifier output on/off. Multiple outputs can be on simultaneously.
7. **MUTE:** Switch with red LED indicator cuts signal to all amplifier outputs.

REAR PANEL FEATURES

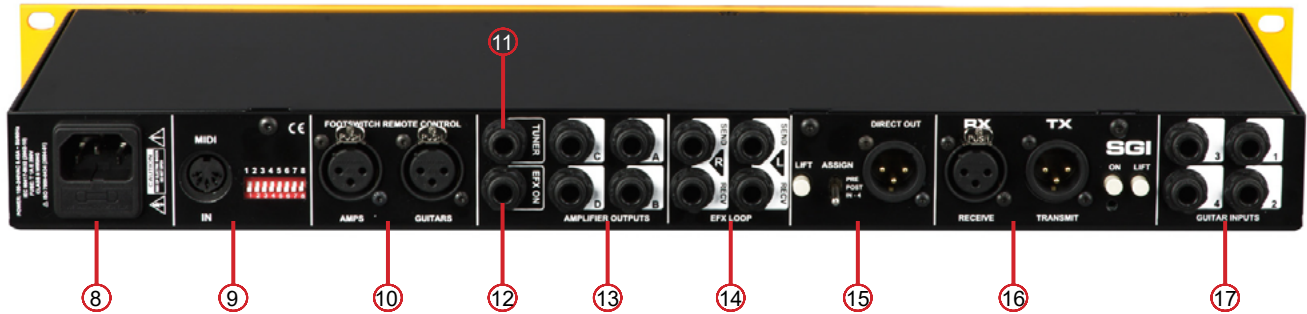

- 8. **IEC POWER:** Connection for standard IEC power cable (included). 100/240V operation for international use.
- 9. **MIDI IN:** Standard 5-pin MIDI connector allows MIDI controllers to activate the inputs and outputs of the JX44 V2. Eight dip switches configure channel, program, and control changes. Can be used in conjunction with JR-5 remote footswitches.
- 10. **REMOTE FOOTSWITCH:** XLR connections for optional JR-5 remote footswitches, which can control either the instrument inputs or the amplifier outputs. Two JR-5 footswitches can be used simultaneously.
- 11. **TUNER OUT:** Buffered unbalanced output to feed a separate tuner. This output is fed by all inactive instrument inputs and will always be active even if the Mute switch is engaged.
- 12. **EFX LOOP REMOTE:** ¼" TRS jack for connection to standard momentary footswitches to turn on/off the EFX Loop remotely or mute the outputs of the JX44.
- 13. **OUTPUTS 1-4:** Transformer-isolated and buffered gold-contact outputs for feeding up to four stage amplifiers.
- 14. **STEREO EFX LOOP:** ¼" TS send and receive connections for local effects pedal chains.
- 15. **DIRECT OUTPUT:** Balanced XLR output to feed a mixer or recording interface. Lift switch disconnects pin-1 to eliminate hum and buzz. The Assign switch selects whether the Direct Out is fed a pre- or post-EFX signal, or instrument input 4 exclusively.
- 16. **SGI RX/TX:** Balanced SGI loop works with the optional SGI to drive long cable runs to and from a remote pedalboard. Includes ground lift switch and SGI on/off switch.
- 17. **INPUTS 1-4:** Connections for unbalanced instruments such as guitars and basses. Wired in parallel with front panel connectors.



GETTING STARTED: POWERING THE JX44

The JX44 features a rear-panel IEC input for the included power supply cable. The internal power supply is compatible for use in multiple regions, from 100-240VAC at 50/60Hz. For international touring applications, simply swap out the IEC cable for one that matches the outlet type for your country of destination.

The JX44 has no power on/off switch: once it is connected to a power source, the front panel LED indicators for Input-1 and Output-A will illuminate, and the unit will be ready for use.

THE INSTRUMENT INPUTS

The JX44 is equipped with four instrument inputs, accessible via redundant connectors on both the front and rear panels. These inputs employ Radial's proprietary Class-A buffer circuit for superior audio quality and low noise, with gold-contact connectors for optimal signal transfer. If your setup includes wireless guitar systems, connect the outputs of your receivers to the instrument inputs. If not, you can connect your guitars or basses directly to the JX44. In either case, use standard 1/4" unbalanced instrument cables, and keep your cable runs as short as you reasonably can.



The instrument inputs, mirrored on the front and rear panels of the JX44

You can activate any input on the JX44 by pressing the corresponding front-panel ON switch. Each switch is backlit and will illuminate when the input is selected. To deselect any instrument, press the ON switch a second time. The JX44 allows any combination of inputs to be active simultaneously, which can be particularly helpful for guitar techs who need to perform a quick instrument hand-off between songs; by making two instruments active, they can let one guitar ring out at the end of the first song, while ensuring the next guitar is ready to play as soon as it reaches the artist's hands.

Note that the front panel inputs have priority over the rear panel connectors - as soon as you plug a cable into one of the front panel input jacks, the corresponding input on the rear panel will be deactivated. This allows you to troubleshoot or make changes on the fly without the need to fuss with cables in the back of your equipment rack during a performance.

Instrument Input-4 is unique in that it may be exclusively assigned to the JX44's direct output. See the direct output section of this manual for more information on using this feature.

THE AMPLIFIER OUTPUTS

The four amplifier outputs on the rear panel of the JX44 are ¼" unbalanced connections that can be used to feed instrument amplifiers, digital amp modelers, or even direct boxes. These outputs are all equipped with industry-leading Jensen transformers for exceptional frequency response with minimal signal coloration, while also providing galvanic isolation that eliminates hum and buzz from ground loops.

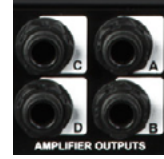

The amplifier outputs

Each amplifier output can be selected using the front panel ON buttons, or remotely with the optional JR-5 footswitch. The front panel ON switches will illuminate to show which outputs are currently active. As with the instrument inputs, you can activate multiple amp outputs at the same time.



The front panel amplifier output controls

All amplifier outputs are equipped with three additional front-panel controls:

- **EFX Assign** Assigns the left or right channel of the EFX Loop to an amplifier output. When the middle DRY setting is selected, no effects will be present at the corresponding amplifier output.
- **Lift** Isolates the ground connection to reduce hum and buzz caused by ground loops.
- **180°** Polarity reverse switch is used to set the absolute phase between multiple amps.

THE MUTE SWITCH

The front panel mute switch provides guitar techs with a quick and easy way to silence the amplifier outputs of the JX44 during troubleshooting or when an artist wishes to quietly tune an instrument, such as an acoustic guitar, on stage.

When the mute switch is pressed, the red LED indicator below the switch illuminates, and all four amplifier outputs are turned off. The EFX Loop outputs, the direct output, and the tuner output will all remain active when the mute switch is engaged.



The Mute switch

The mute function of the JX44 can also be remotely accessed using the JR-5 footswitch for amplifier control, using a momentary switch connected to the EFX ON jack, or via the MIDI input. Each of these cases will cause the front panel mute LED to illuminate, indicating that outputs have been turned off. Please see the JR-5 remote, EFX Loop remote, and MIDI sections of this manual for further details.

THE STEREO EFX LOOP

The JX44's Stereo EFX Loop provides the ability to connect to guitar pedals or rackmount effects processors and share them across all four instrument inputs. The EFX Loop can also be individually assigned to each of the amplifier outputs, making it easy to accommodate wet/dry or wet/dry/wet stage amp setups.

Connections to the EFX Loop are made at the rear panel of the JX44 using standard ¼" unbalanced instrument cables. The left and right SEND jacks are buffered outputs that feed the inputs of your effects devices, while the RECV (receive) jacks take the processed signals back into the JX44 to feed the amplifier outputs.

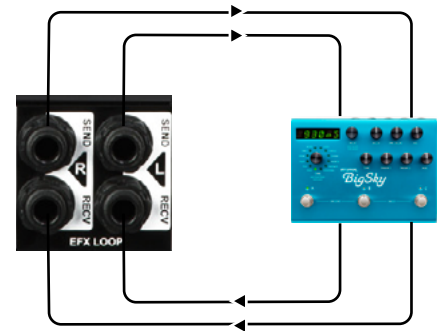

Connecting guitar pedals to the EFX Loop



The EFX Assign switch for Amp-A

You can choose to feed the left or the right channel of the EFX Loop to each of the JX44 amplifier outputs using the EFX Assign switches on the front panel. For example, you can have Output-A set to L, and Output-B set to R, allowing for stereo playback when both amplifiers are active.

Mono guitar pedals and effects can also be connected to the EFX Loop. This allows the Stereo EFX Loop to operate as if it were two separate mono loops, so you can use the left and right sides for separate pedal chains and assign them to different amplifiers.

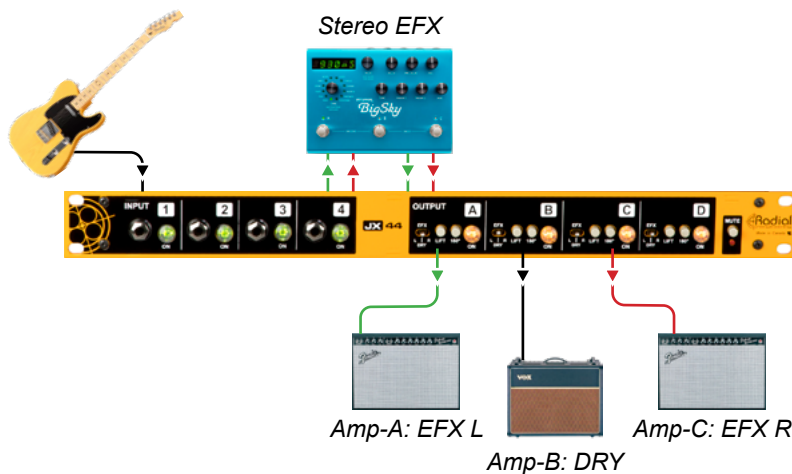

Example: Using the JX44 for wet/dry/wet stage setups

When the EFX Assign switch is set to the middle DRY setting, this means that neither channel of the Stereo EFX Loop will be heard at the corresponding amplifier output; the JX44 will simply bypass your stereo effects before feeding signal to that amplifier.

This is useful when you only want the EFX Loop active on some of your stage amplifiers. The example to the left shows a setup that uses two amplifiers to output effects in stereo, while adding a third 'dry' amplifier with no effects to retain the presence of the original guitar signal.

If you are using the SGI Loop (detailed on page 10), keep in mind that your remote pedalboard effects will still be present on all amp outputs, even those set to DRY.

THE EFX LOOP REMOTE INPUT

The rear panel EFX ON jack allows you to connect a footswitch to remotely turn the Stereo EFX Loop on and off. Any standard footswitch wired as a normally open, **non-latching momentary** switch may be used. The Radial JR-1M is an example of a momentary footswitch that is compatible with the EFX ON input (note JR-1M will need to be used in passive mode, as the LEDs on the footswitch will not illuminate when used with the JX44). The ability to remotely control the EFX Loop can also be accessed via MIDI, as described later in this manual.



The EFX ON remote input jack

Note that if you are having an issue where it appears the EFX Loop is not passing any signal, it may be the case that the EFX ON/OFF function has been left in the OFF position. You can check this by connecting a momentary footswitch and toggling the switch. If you don't have a footswitch available, you can use a standard 1/4" TS guitar cable to this input and short the tip to the shield on the other end of the cable, as this will also reactivate the EFX Loop.

NORMAL MODE VS WET/DRY/WET MODE



Rear panel dip switches 1-8

The EFX ON jack has two modes of operation: 'normal' mode and 'wet/dry/wet' mode. You can toggle between these modes using dip switch #8, which is found on the rear panel next to the MIDI connector. Set switch 8 in the UP position for 'normal' mode, and DOWN for 'wet/dry/wet' mode.

In 'normal' mode, a footswitch connected to this jack will turn off the Stereo EFX Loop, while still feeding your dry guitar signal to any active amplifier outputs. This causes the EFX ON jack to work the same way as a footswitch input on an amplifier with an FX loop - it acts like a bypass switch, so you can turn on and off your time-based effects as needed without muting the amp. If you are using a remote pedalboard in conjunction with the JX44's SGI Loop, this will be unaffected by any switch connected to the EFX ON jack.



The EFX ON is in 'normal' mode when DIP switch #8 is in the UP position

In 'wet/dry/wet' mode, the EFX ON jack can be used to mute any amps that you have assigned to the left or right channels of the Stereo EFX Loop. This is particularly helpful for players with wet/dry/wet setups since they will have dedicated amplifiers for each channel of the EFX Loop, as well as a dedicated 'dry' amplifier. With one press of a footswitch, you can mute all of the 'wet' amplifiers simultaneously, leaving only the 'dry' amp active. Note that in 'wet/dry/wet' mode, muting the EFX Loop will also mute the Direct out when it is assigned to the POST setting (see page 9 for details).

ALTERNATE USE AS A MUTE SWITCH

The EFX ON jack can also be used to allow a simple footswitch to remotely mute all four amplifier outputs, mirroring the operation of the JX44's front panel mute switch. When using a footswitch for this purpose, the front panel Mute LED will illuminate and all signal to the amplifier outputs will be muted.

To access the mute switch feature of the EFX ON jack, ensure that you are using a footswitch with a 1/4" TRS connector and that it is wired to connect the ring to the sleeve when pressed. If the footswitch is wired to connect the tip to the sleeve when pressed, it will instead control the EFX Loop on/off feature of the JX44 as described above.

THE TUNER OUTPUT

The tuner output on the rear panel of the JX44 is an unbalanced 1/4" connection designed to feed a tuner pedal or rackmount guitar tuner. This output is buffered to remove the tuner from the signal chain and prevent clock noise from bleeding onto the primary audio signal path.

The tuner output is fed from all inactive instrument inputs. So if you have Input-1 and Input-2 active, then Input-3 and Input-4 will both feed the tuner out. This makes it easy for guitar techs to tune unused instruments at any given time without disrupting the performance.



The Tuner output

THE DIRECT OUT

The JX44 is equipped with a Direct output for connecting to mixing consoles when using acoustic instruments, or for capturing a performance or rehearsal by connecting to a recording interface. This output features a premium Jensen transformer for exceptional audio quality and isolation to prevent noise from ground loops.



The Direct Out

Use balanced XLR cables to connect the Direct out to the mic-level input of your mixer or interface. The Direct out section incorporates two additional switches:

- **Lift** Ground lift switch isolates pin-1 on the Direct out XLR to reduce buzz and hum caused by ground loops.
- **Assign** This three-position switch selects which inputs will feed the Direct output:

When set to PRE, all active inputs are routed to the Direct out before any effects are applied from either the SGI Loop or the EFX Loop.

In the POST setting, all active inputs feed the direct out after effects have been added from both the SGI Loop and the EFX Loop. The left and right channels of the EFX Loop are blended together equally to feed the Direct out.

When set to IN-4, the fourth instrument input is always feeding the Direct out while inputs 1-3 are excluded. When IN-4 is selected, no effects will feed the Direct out from either the SGI Loop or the EFX Loop, and instrument Input-4 will always be active through the Direct out regardless of whether the front panel ON switch is engaged for that input.

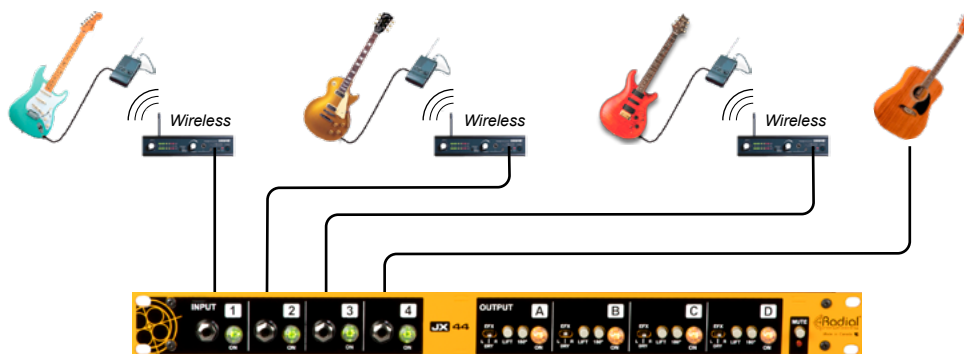

When using the JX44 with both electric and acoustic instruments, connect the acoustic to Input-4 and assign it to the Direct output.

THE SGI LOOP

Running unbalanced guitar cables over long distances can result in noise and interference on the audio signal and/or unwanted alterations to your tone. This problem is particularly acute on large stages, where it is common to send instrument signals from the backline (where the wireless receivers and the JX44 are located) to a pedalboard at the artist's feet and back again.

To address this issue, the JX44 comes equipped with a dedicated SGI Loop that allows you to connect to remote pedalboards using balanced XLR mic cables, providing the ability to send your guitar signals up to 100 meters (300 feet) without noise or tone loss.

The SGI Loop utilizes the Radial SGI Line Isolator System's TX and RX units, which can be mounted on a remote pedalboard to act as an interface between the JX44 and your guitar pedals, converting low-impedance signals from the JX44's XLR connections to high-impedance signals required for connecting over 1/4" to your guitar pedals.



The SGI remote line drivers

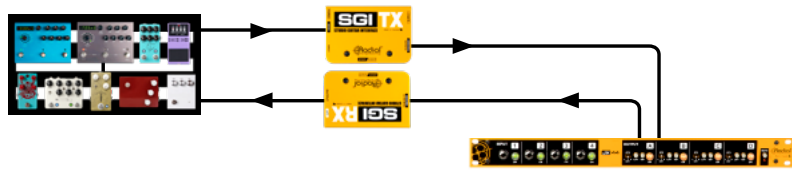

Using the SGI with the JX44 to connect remote effect pedals

The SGI Loop section on the rear panel of the JX44 includes two XLR connections, one TX (Transmit) male XLR to feed the SGI-RX at the remote pedalboard, and one RX (Receive) female XLR to accept the return signal from the SGI-TX. Both XLRs are equipped with premium Jensen transformers to ensure the best possible audio quality and eliminate hum and buzz from ground loops. The SGI Loop section also features two switches:



The SGI Loop section on the JX44 rear panel.

- **On** Activates the SGI Loop and illuminates the LED just below the switch.
- **Lift** Ground lift isolates pin-1 on the RX XLR input to further reduce buzz and hum caused by ground loops.

When the On switch is engaged, the SGI Loop feeds all active instrument inputs and

sends those signals to the remote SGI units and back before feeding any active amplifier outputs, even if they are assigned to the DRY setting.

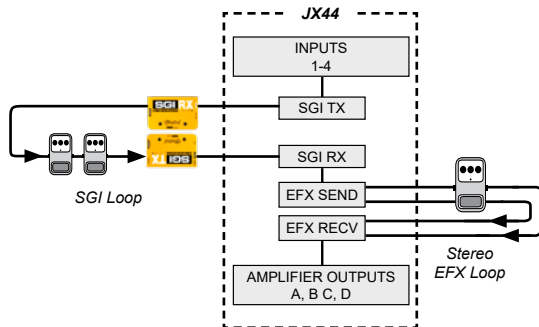

Amplifiers assigned to L or R using the front panel switches will include signal from both the SGI Loop and the Stereo EFX Loop

If you are also using the local Stereo EFX Loop on the JX44, this feature will directly follow the SGI Loop in the signal path, as shown in the adjacent block diagram. In this case, the SGI Loop will insert your remote pedalboard into the signal path after the instrument input section, and before the local Stereo EFX Loop. This means any active instruments will feed your pedalboard first, which will then, in turn, feed any stereo effects connected to the JX44 (the SGI Loop will feed the left and right sides of the EFX Loop equally).

Any amplifier assigned to L or R will therefore include both the SGI Loop and the Stereo EFX Loop in the signal path, while amps assigned to DRY will only include the signal from the SGI Loop.

CONNECTING THE SGIs

Begin by mounting both SGI units on your remote pedalboard and connecting the included 15VDC power supply to the SGI-TX (if using the original SG1 15V version). Or (if using the updated SGI 9V) any 9-18V outlet on your multi-output pedal power supply. Once connected, the POWER LED on the SGI-TX will illuminate.

Next, using standard ¼" guitar cables, connect the input of your effects chain to the SGI-RX's ¼" input jack. Connect the effects chain's output to the ¼" input jack on the SGI-TX.

Then make the balanced connections between the JX44 and the SGIs using XLR mic cables. The TX (transmit) output from the JX44 connects to the SGI-RX. The SGI Loop is completed by connecting the output from the SGI-TX to the RX input on the JX44.

Once your cables are connected, engage the SGI ON switch on the rear panel of the JX44. An LED below this switch will illuminate to indicate that the SGI Loop is active, and you will hear your pedalboard effects across any active amplifier output, regardless of whether the EFX Assign switch is set to L, R, or DRY.

Both the JX44 and the SGIs are isolated with Jensen Transformers to eliminate noise caused by ground loops. If you hear hum or buzz after connecting and testing the SGI Loop, try toggling the Lift switches on both the SGI-RX and on the rear panel of the JX44.

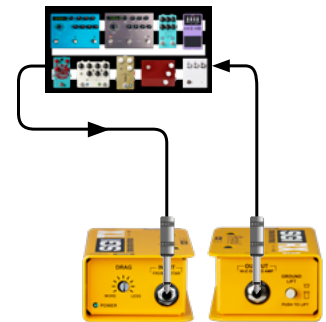

The ¼" connections from the SGI units to a pedalboard.



The balanced XLR connections from the SGIs to the JX44.

EXAMPLE: WIRELESS GUITARS AND A REMOTE PEDALBOARD

In this application, the JX44 is located near the player's wireless receivers and guitar amplifiers. The SGI TX, RX, and JR-5 are mounted on the player's pedalboard. The signal originates at the guitar through the wireless link to the receiver. From the receiver, it flows into the JX44 inputs. At this point, the SGI Loop sends the signal out to the pedals and back again via the SGIs. The artist can enjoy the freedom of a wireless guitar connection and place their pedals at their stage position along with the JR-5 to remotely control amplifier or instrument switching.

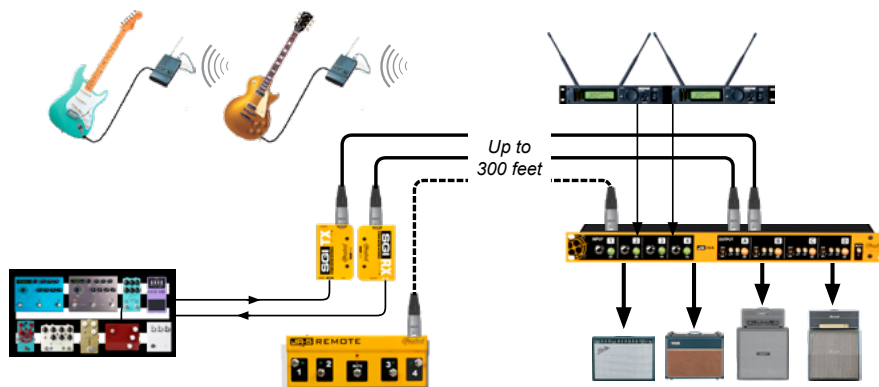

Using the SGI Loop on the JX44 with a wireless guitar system.

THE JR-5 REMOTE FOOTSWITCH

The JX44 is compatible with the optional Radial JR-5 Remote, a rugged footswitch that can control the instrument or the amplifier switching functions from up to 300 feet away. This gives guitar technicians the ability to manage inputs and outputs hands-free, or it can allow the artist to control the JX44 from their pedalboard on stage.

The JR-5 connects to the JX44 using a standard XLR mic cable. No local power supply is required, as the JR-5 receives power automatically from the JX44. You can use the JR-5 to remotely switch guitar inputs or amplifier outputs, or you can use two JR-5 remotes simultaneously to control both features.



The JR-5 remote inputs

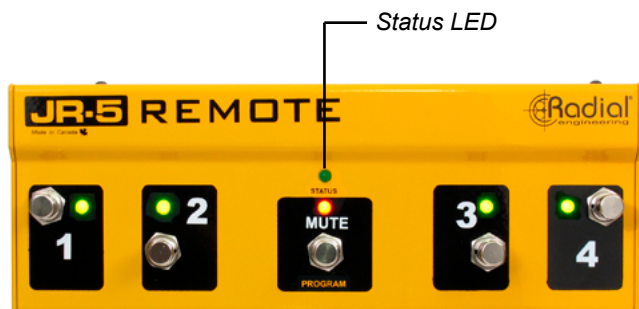

The JR-5 Remote Footswitch

USING THE JR-5 FOR GUITARS

To control the instrument inputs with the JR-5, connect it to the XLR input labelled GUITARS. The footswitches 1-4 on the JR-5 will perform the same function as the ON switches on the front panel of the JX44, complete with LED indicators to let you know at a glance which instruments are currently active.

In addition to the input selector footswitches, the JR-5 includes a MUTE switch. When pressed, this will temporarily mute all amplifier outputs on the JX44. Pressing this switch a second time will revert back to the prior combination of active outputs.

USING THE JR-5 FOR AMPLIFIERS

To control the amplifier outputs with the JR-5, connect to the XLR marked AMPS. The footswitches 1-4 on the JR-5 will now control the ON switches on the JX44 for the amplifier outputs. When selecting amplifiers with the JR-5 remote, the LED status indicators on the front panel of the JX44 will also turn on/off to mirror your selections.

When used for amplifier switching, the center MUTE footswitch on the JR-5 duplicates the JX44's front panel mute control. Both switches can be used to silence the amplifier outputs of the JX44, and their LED indicators sync together to display the current mute status at both locations.

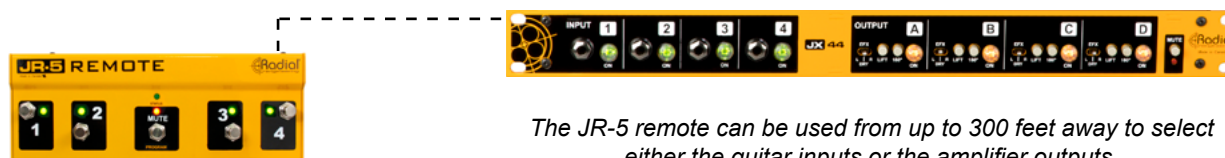

The JR-5 remote can be used from up to 300 feet away to select either the guitar inputs or the amplifier outputs.

USING THE JR-5 TO STORE AND RECALL BANKS

The JR-5 can also be operated in BANK mode, which stores up to four combinations of instrument or amplifier on/off settings, eliminating excess toe-tapping during complex performances. BANK mode can be accessed when using the JR-5 for either guitar or amplifier switching.

When the JR-5 is operating in BANK mode, the JX44 front panel switches will still function as typical on/off switches for each input or output. This scenario allows you to recall four banks with the JR-5 footswitch while using the JX44 front panel controls to temporarily add or subtract instruments/amplifiers.

PROGRAMMING BANKS WITH THE JR-5 FOOTSWITCH

Besides manually controlling the JX44 inputs or outputs, the JR5 also has the ability to program and store its own set of four banks. The following steps outline this procedure:

- Hold down the MUTE footswitch for 8 seconds.
- The MUTE LED indicates the bank you are currently programming by the number of blinks. Select the desired combination of guitar inputs/amplifier outputs using the footswitches 1 through 4. Hit the MUTE footswitch to write the bank to memory and advance to the next bank.
- Repeat until all four banks are set up and stored. Hold the MUTE footswitch for 3 seconds when finished.

RECALLING BANKS

- Hold the MUTE footswitch for 3 seconds to enter BANK mode. The STATUS LED on the JR-5 will illuminate, indicating BANK mode is active.
- Use the footswitches 1 through 4 to recall the four banks from the JR-5's internal memory.
- You can exit BANK mode at any time by holding the MUTE footswitch for 3 seconds until the STATUS LED turns off.

THE MIDI INPUT

The JX44 features built-in MIDI compatibility for use with MIDI footswitches and controllers. This allows you to remotely control the instrument inputs and the amplifier outputs from a single device. To use these devices with the JX44, connect their MIDI output to the rear panel MIDI IN of the JX44 using a standard 5-pin MIDI cable.

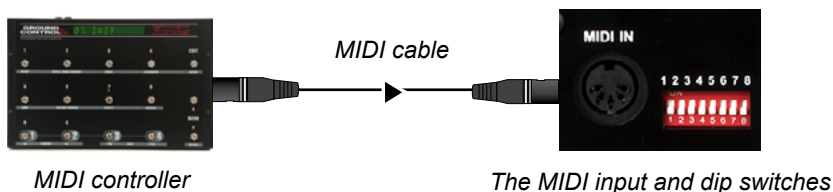

MIDI CONFIGURATION

The JX44's MIDI channel selection and configuration are set via the 8 DIP switches on the rear panel. It can be set up to respond to an individual MIDI channel (1-16) or put into OMNI mode to respond to messages sent on all MIDI channels simultaneously. The DIP switches also determine whether the JX44 responds to MIDI Program Change or Control Change messages. DIP switch details can be found on the following pages.

THE DEFAULT FACTORY DIP SWITCH SETTINGS

The JX44 ships with Dip switches 1-4: DOWN, and 5-8: UP. This configuration means the JX44 will respond to MIDI messages on all MIDI Channels (OMNI mode), and the JX44 will respond to Control Change messages only.

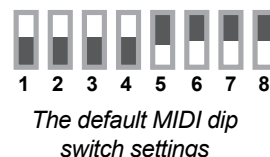

DIP switches 1-4:

These four switches select which MIDI channel (1-16) the JX44 will respond to. The guide below shows which position each switch should be in for each corresponding channel.

DIP SWITCH #	1	2	3	4
Midi Ch 1	DOWN	DOWN	DOWN	DOWN
Midi Ch 2	DOWN	DOWN	DOWN	UP
Midi Ch 3	DOWN	DOWN	UP	DOWN
Midi Ch 4	DOWN	DOWN	UP	UP
Midi Ch 5	DOWN	UP	DOWN	DOWN
Midi Ch 6	DOWN	UP	DOWN	UP
Midi Ch 7	DOWN	UP	UP	DOWN
Midi Ch 8	DOWN	UP	UP	UP
Midi Ch 9	UP	DOWN	DOWN	DOWN
Midi Ch 10	UP	DOWN	DOWN	UP
Midi Ch 11	UP	DOWN	UP	DOWN
Midi Ch 12	UP	DOWN	UP	UP
Midi Ch 13	UP	UP	DOWN	DOWN
Midi Ch 14	UP	UP	DOWN	UP
Midi Ch 15	UP	UP	UP	DOWN
Midi Ch 16	UP	UP	UP	UP

DIP switch 5:

This switch is used to select OMNI mode. OMNI Mode allows the JX44 to respond to Control and Program changes on any MIDI channel (1-16). Setting the JX44 to a specific channel is particularly useful when linking multiple MIDI devices as they can all be set to only respond to changes on their assigned channel.

This switch is used to select OMNI mode. OMNI Mode allows the JX44 to respond to Control and Program changes on any MIDI channel (1-16). Setting the JX44 to a specific channel is particularly useful when linking multiple MIDI devices, as they can all be set to only respond to changes on their assigned channel.

When in the DOWN position, OMNI mode is OFF, and the JX44 will only respond to MIDI messages on the channel selected with switches 1-4. When in the UP position, OMNI mode is ON, and the JX44 will respond to MIDI messages sent on all MIDI channels.



Select OMNI mode by setting DIP switch #5 in the UP position

DIP switches 6-7:

The JX44 features can be activated using MIDI Control Changes, Program Changes, or both. Switches 6 and 7 select how the JX44 will respond to these messages. If both switches are in the same position, the JX44 will respond to both Control Changes and Program Changes.

DIP #	6	7
Enable Control Changes	DOWN	UP
Enable Program Changes	UP	DOWN
Enable Program Changes and Control Changes	UP	UP
Enable Program Changes and Control Changes	DOWN	DOWN

DIP switch 8:

Dip switch 8 is used to toggle between two modes of operation for the stereo EFX Loop. When switch 8 is in the default UP position, the JX44 is in 'normal' mode. When switch 8 is moved to the DOWN position, 'wet/dry/wet' mode is activated. Please see page 8 of this manual for further details on this feature.

MIDI IMPLEMENTATION CHART

The JX44 is set up to respond to both MIDI Control changes and Program changes. Control changes can select both guitars and amplifiers on the JX44, while Program changes are reserved for amplifier selection only. The following chart shows which instruments and amplifiers will be activated when the JX44 receives the various Control and Program changes sent by your MIDI pedalboard or sequencer:

	GUITAR 1	GUITAR 2	GUITAR 3	GUITAR 4	Amp Out A	Amp Out B	Amp Out C	Amp Out D
CC 88 (off 0-63/on 64-127)*	ON							
CC 89 (off 0-63/on 64-127)		ON						
CC 90 (off 0-63/on 64-127)			ON					
CC 91 (off 0-63/on 64-127)				ON				
CC 92 (off 0-63/on 64-127)					ON			
CC 93 (off 0-63/on 64-127)						ON		
CC 94 (off 0-63/on 64-127)							ON	
CC 95 (off 0-63/on 64-127)								ON
CC 96 (off 0-63/on 64-127)					MUTE ON/OFF			
CC 97 (off 0-63/on 64-127)					EFX SEND ON/OFF			
Program C1					ON			
Program C2						ON		
Program C3							ON	
Program C4								ON
Program C5					ON	ON		
Program C6					ON	ON	ON	
Program C7					ALL AMPS ON			
Program C8							ON	ON
Program C9						ON	ON	ON
Program C10					ON		ON	ON
Program C11					ON	ON		ON
Program C12						ON	ON	
Program C13					ON			ON
Program C14					ON		ON	
Program C15						ON		ON
Program C16					ALL AMPS OFF			
Program C17 (Mute)					ALL MUTE ON			
Program C18 (Unmute)					ALL MUTE OFF			
Program C19 (EFX on)					EFX ON			
Program C20 (EFX off)					EFX OFF			

*Control change messages consist of a controller number (ex. CC 88) and a value which ranges from 0-127. Sending a CC message with a value from 0-63 will cause the related function on the JX44 to turn OFF, while values from 64-127 will result in the feature turning ON.

JX44 V2 SPECIFICATIONS*

ANY INSTRUMENT INPUT TO ANY AMP OUTPUT

Frequency Response:20Hz-20kHz +/-0.2dB, 10Hz-100kHz +/-1dB (0dBv)
 Gain: +/-0.3dB
 Maximum Input:+18dBu (Output 1% THD @ 1kHz), +17dBu (Output 0.1% THD @ 1kHz)
 Total Harmonic Distortion + Noise:0.001%, -100dB (@ 1kHz, 0dBu)
 Total Harmonic Distortion:0.0006%, -105dB (@ 1kHz, 0dBu)
 Signal to Noise Ratio:-102dB (referenced to 0dBu), -118dB (referenced to +18dBu)

SGI REMOTE EFFECTS LOOP

Gain change with SGI Inserted:..... +/-0.5dB
 Frequency Response change with SGI Inserted:20Hz-20kHz +/-0.1dB

DIRECT OUTPUT

Output Attenuation:.....-21dB +/-1dB
 Frequency Response:20Hz-20kHz +/-0.2dB, 10Hz-50kHz +/-1dB

GENERAL

Conditions:.....For use in dry locations only between 5°C and 40°C
 Power:100V to 240V, 50/60Hz with IEC connection
 Conformity:.....CE, FCC
 Warranty:Radial 3-year, transferable

*Specifications are subject to change without notice.

**RADIAL ENGINEERING LTD.
3 YEAR TRANSFERABLE WARRANTY**

RADIAL ENGINEERING LTD. ("Radial") warrants this product to be free from defects in material and workmanship and will remedy any such defects free of charge according to the terms of this warranty. Radial will repair or replace (at its option) any defective component(s) of this product (excluding finish and wear and tear on components under normal use) for a period of three (3) years from the original date of purchase. In the event that a particular product is no longer available, Radial reserves the right to replace the product with a similar product of equal or greater value. To make a request or claim under this limited warranty, the product must be returned prepaid in the original shipping container (or equivalent) to Radial or to an authorized Radial repair center, and you must assume the risk of loss or damage. A copy of the original invoice showing date of purchase and the dealer name must accompany any request for work to be performed under this limited and transferable warranty. This limited warranty shall not apply if the product has been damaged due to abuse, misuse, misapplication, accident, or as a result of service or modification by any other than an authorized Radial repair center.

THERE ARE NO EXPRESSED WARRANTIES OTHER THAN THOSE ON THE FACE HEREOF AND DESCRIBED ABOVE. NO WARRANTIES, WHETHER EXPRESSED OR IMPLIED, INCLUDING BUT NOT LIMITED TO, ANY IMPLIED WARRANTIES OF MERCHANTABILITY OR FITNESS FOR A PARTICULAR PURPOSE, SHALL EXTEND BEYOND THE RESPECTIVE WARRANTY PERIOD DESCRIBED ABOVE OF THREE YEARS. RADIAL SHALL NOT BE RESPONSIBLE OR LIABLE FOR ANY SPECIAL, INCIDENTAL, OR CONSEQUENTIAL DAMAGES OR LOSS ARISING FROM THE USE OF THIS PRODUCT. THIS WARRANTY GIVES YOU SPECIFIC LEGAL RIGHTS, AND YOU MAY ALSO HAVE OTHER RIGHTS, WHICH MAY VARY DEPENDING ON WHERE YOU LIVE AND WHERE THE PRODUCT WAS PURCHASED.

To meet the requirements of California Proposition 65, it is our responsibility to inform you of the following:

WARNING: This product contains chemicals known to the State of California to cause cancer, birth defects or other reproductive harm.

Please take proper care when handling and consult local government regulations before discarding.

All trademarks belong to their respective owners. All references to these are for example only and are not associated with Radial.



Radial Engineering Ltd.
1165-1845 Kingsway Ave, Port Coquitlam BC V3C 0H3
Tel: 604-942-1001 • www.radialeng.com
Email: info@radialeng.com

